



OPERATING INSTRUCTIONS

MATRIX AMPLIFIER

MA-725F

MATRIX PRE-AMPLIFIER

MM-700F

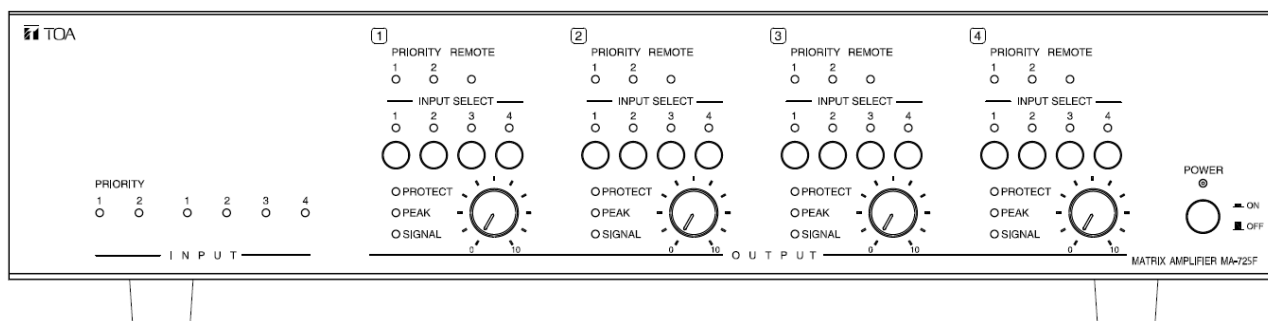

Thank you for purchasing TOA's Matrix Amplifier.

Please carefully follow the instructions in this manual to ensure long, trouble-free use of your equipment.

TOA Corporation

TABLE OF CONTENTS

1.	IMPORTANT SAFETY INSTRUCTIONS	3
2.	SAFETY PRECAUTIONS	4
3.	GENERAL DESCRIPTION	7
4.	FEATURES	8
5.	HANDLING PRECAUTIONS	8
6.	INSTALLATION PRECAUTIONSS	9
7.	NOMENCLATURE AND FUNCTIONS	10
	[Front]	10
	[Rear]	11
8.	CONNECTION EXAMPLES	15
9.	CONNECTION	17
9.1.	Removable Terminal Plug Connection	17
9.2.	How to Connect Input Signals	18
9.3.	Speaker Output Signal Connections	18
9.4.	MOH Output Connections	19
9.5.	LINE Output Connections	19
9.6.	Remote Control Equipment Connections	20
10.	MUTING FUNCTIONS	21
10.1.	Manual Mute	21
10.2.	Auto Mute	22
10.3.	Priority Mix	23
11.	OPERATION	23
11.1	Input Selection Function	23
11.2	EQ Preset Selections	24
11.3	Using the WP-700 Remote Controller	28
12.	RACK MOUNTING BRACKET ATTACHMENT	29
13.	PROTECTION	29
14.	BLOCK DIAGRAMS	30
15.	DIMENSIONAL DIAGRAM	32
16.	SPECIFICATIONS	33

1. IMPORTANT SAFETY INSTRUCTIONS

- Read these instructions.
- Keep these instructions.
- Heed all warnings.
- Follow all instructions.
- Do not use this apparatus near water.
- Clean only with dry cloth.
- Do not block any ventilation openings. Install in accordance with the manufacturer's instructions.
- Do not install near any heat sources such as radiators, heat registers, stoves, or other apparatus (including amplifiers) that produce heat.
- Do not defeat the safety purpose of the polarized or grounding-type plug. A polarized plug has two blades with one wider than the other. A grounding type plug has two blades and a third grounding prong. The wide blade or the third prong are provided for your safety. If the provided plug does not fit into your outlet, consult an electrician for replacement of the obsolete outlet.
- Protect the power cord from being walked on or pinched particularly at plugs, convenience receptacles, and the point where they exit from the apparatus.
- Only use attachments/accessories specified by the manufacturer.
- Use only with the cart, stand, tripod, bracket, or table specified by the manufacturer, sold with the apparatus. When a cart is used, use caution when moving the cart/apparatus combination to avoid injury from tip-over.
- Unplug this apparatus during lightning storms or when unused for long periods of time.
- Refer all servicing to qualified service personnel. Servicing is required when the apparatus has been damaged in any way, such as power-supply cord or plug is damaged, liquid has been spilled or objects have fallen into the apparatus, the apparatus has been exposed to rain or moisture, does not operate normally, or has been dropped.



INSTRUCTIONS ESSENTIELLES POUR LA SÉCURITÉ

- Lire ces instructions.
- Conserver ces instructions pour référence ultérieure.
- Respecter tous les avertissements.
- Suivre toutes les instructions.
- Ne pas utiliser cet appareil à proximité d'eau.
- Nettoyer uniquement à l'aide d'un chiffon sec.
- Ne pas obstruer les orifices de ventilation. Installer conformément aux instructions du fabricant.
- Ne pas installer à proximité de sources de chaleur telles que des radiateurs, des registres thermiques, des chaudières ou d'autres appareils (notamment des amplificateurs) produisant de la chaleur.
- Ne pas contourner la fonction de sécurité de la fiche polarisée ou de mise à la terre. Une fiche polarisée est équipée de deux broches, dont l'une est plus large que l'autre. Une fiche de mise à la terre est équipée de deux broches et d'une troisième pour la mise à la terre. Cette dernière, la plus large, est prévue à des fins de sécurité. Si la fiche fournie ne peut être insérée dans la prise électrique souhaitée, consulter un électricien pour faire remplacer cette dernière.
- Protéger le cordon d'alimentation pour éviter qu'il ne soit piétiné ou pincé, notamment au niveau des fiches, des prises de courant ou de son point de sortie de l'appareil.
- Utiliser uniquement les accessoires spécifiés par le fabricant.
- Utiliser uniquement avec le chariot, support, trépied, la patte de montage ou la table spécifiés par le fabricant ou vendus avec l'appareil. En cas d'utilisation d'un chariot, manipuler la combinaison chariot/appareil pour éviter les blessures dues à un renversement.
- Débrancher cet appareil pendant les orages ainsi que lorsqu'il reste inutilisé pendant une période prolongée.
- La maintenance de l'appareil doit être confiée à un technicien après-vente qualifié. Une maintenance s'avère nécessaire si l'appareil est endommagé (au niveau du cordon d'alimentation ou de la fiche), a été mouillé par un liquide, un objet est tombé à l'intérieur, s'il a été exposé à la pluie ou l'humidité, s'il ne fonctionne pas normalement ou s'il est tombé.



FCC REQUIREMENTS

Note: This equipment has been tested and found to comply with the limits for a Class A digital device, pursuant to part 15 of the FCC Rules. These limits are designed to provide reasonable protection against harmful interference when the equipment is operated in a commercial environment. This equipment generates, uses, and can radiate radio frequency energy and, if not installed and used in accordance with the instruction manual, may cause harmful interference to radio communications. Operation of this equipment in a residential area is likely to cause harmful interference in which case the user will be required to correct the interference at his own expense.

- Reorient or relocate the receiving antenna.
- Increase the separation between the equipment and receiver.
- Connect the equipment into an outlet on a circuit different from that to which the receiver is connected.
- Consult the dealer or an experienced radio/TV technician for help.

- This Class A digital apparatus complies with Canadian ICES-003.
- Cet appareil numérique de la classe A est conforme à la norme NMB-003 du Canada.

2. SAFETY PRECAUTIONS

- Before installation or use, be sure to carefully read all the instructions in this section for correct and safe operation.
- Be sure to follow all the precautionary instructions in this section, which contain important warnings and/or cautions regarding safety.
- After reading, keep this manual handy for future reference.

Safety Symbol and Message Conventions

Safety symbols and messages described below are used in this manual to prevent bodily injury and property damage which could result from mishandling. Before operating your product, read this manual first and understand the safety symbols and messages so you are thoroughly aware of the potential safety hazards.



WARNING

Indicates a potentially hazardous situation which, if mishandled, could result in death or serious personal injury.



CAUTION

Indicates a potentially hazardous situation which, if mishandled, could result in moderate or minor personal injury, and/or property damage.



WARNING

When Installing the Unit

- Do not expose the unit to rain or an environment where it may be splashed by water or other liquids, as doing so may result in fire or electric shock.
- Use the unit only with the voltage specified on the unit. Using a voltage higher than that which is specified may result in fire or electric shock.
- Do not cut, kink, otherwise damage nor modify the power supply cord. In addition, avoid using the power cord in close proximity to heaters, and never place heavy objects -- including the unit itself--on the power cord, as doing so may result in fire or electric shock.

- External wiring connected to the terminals marked with ⚡ requires installation by an instructed person.
- The apparatus shall be connected to a mains socket outlet with a protective earthing connection.

When the Unit is in Use

- Should the following irregularity be found during use, immediately switch off the power, disconnect the power supply plug from the AC outlet and contact your nearest TOA dealer. Make no further attempt to operate the unit in this condition as this may cause fire or electric shock.

- If you detect smoke or a strange smell coming from the unit.
- If water or any metallic object gets into the unit.
- If the unit falls, or the unit case breaks.
- If the power supply cord is damaged (exposure of the core, disconnection, etc.)
- If it is malfunctioning (no tone sounds.)
- To prevent a fire or electric shock, never open nor remove the unit case as there are high voltage components inside the unit. Refer all servicing such as modification inside the unit to qualified service personnel.
- Do not place cups, bowls, or other containers of liquid or metallic objects on top of the unit. If they accidentally spill into the unit, this may cause a fire or electric shock.
- Do not insert nor drop metallic objects or flammable materials in the ventilation slots of the unit's cover, as this may result in fire or electric shock.
- Do not touch a plug during thunder and lightning, as this may result in electric shock.

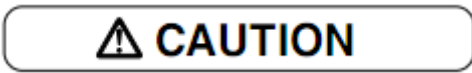

When Installing the Unit

- Never plug in nor remove the power supply plug with wet hands, as doing so may cause electric shock.
- When unplugging the power supply cord, be sure to grasp the power supply plug; never pull on the cord itself. Operating the unit with a damaged power supply cord may cause a fire or electric shock.
- When moving the unit, be sure to remove its power supply cord from the wall outlet. Moving the unit with the power cord connected to the outlet may cause damage to the power cord, resulting in fire or electric shock. When removing the power cord, be sure to hold its plug to pull.
- Avoid installing the unit in humid or dusty locations, in locations exposed to the direct sunlight, near the heaters, or in locations generating sooty smoke or steam as doing otherwise may result in fire or electric shock.

- To avoid electric shocks, be sure to switch off the unit's power when connecting speakers.
- The unit is designed exclusively to be mounted in an equipment rack. Be sure to follow the instructions below when rack-mounting the unit. Failure to do so may cause a fire or personal injury.
- Install the equipment rack on a stable, hard floor. Fix it with anchor bolts or take other arrangements to prevent it from falling down.
- Be sure to use the screws with a diameter of over 5 mm (0.2") and length of over 12 mm (0.47") to mount the unit.
- When connecting the unit's power cord to an AC outlet, use the AC outlet with current capacity allowable to the unit.

When the Unit is in Use

- Make sure to set all output level controls to 0 position before power is switched on.
- Loud noise produced when power is switched on with any of those controls set to the position other than 0 position can impair hearing.
- Do not operate the unit for an extended period of time with the sound distorting. Doing so may cause the connected speakers to heat, resulting in a fire.
- Contact your TOA dealer as to the cleaning. If dust is allowed to accumulate in the unit over a long period of time, a fire or damage to the unit may result.
- If dust accumulates on the power supply plug or in the wall AC outlet, a fire may result. Clean it periodically. In addition, insert the plug in the wall outlet securely.
- Turn off this unit's power switch, and unplug the power supply plug from the AC outlet for safety purposes when cleaning or leaving the unit unused for 10 days or more. Doing otherwise may cause a fire or electric shock.



The lightning flash with arrowhead symbol, within an equilateral triangle, is intended to alert the user to the presence of uninsulated "dangerous voltage" within the product's enclosure that may be of sufficient magnitude to constitute a risk of electric shock to persons.

CONSEILS DE SÉCURITÉ

- Avant l'installation ou l'utilisation, lire attentivement l'ensemble des instructions de cette section pour un fonctionnement correct et sûr.
- Veiller à respecter les précautions recommandées dans cette section, laquelle contient des mises en garde
- et/ou précautions importantes en matière de sécurité.
- Après lecture, conserver ce manuel à portée de main pour consultation ultérieure.

Symboles de sécurité et conventions

Les symboles et messages de sécurité décrits ci-dessous sont utilisés dans cette notice pour prévenir tout dommage corporel ou matériel pouvant résulter d'une mauvaise utilisation. Lire attentivement cette notice pour comprendre parfaitement les symboles et messages de sécurité afin de prévenir tout risque éventuel.

 **AVERTISSEMENT** Indique une situation risquant d'entraîner des blessures graves, voire la mort, en cas de mauvaise manipulation.

 **ATTENTION** Indique une situation risquant d'entraîner des blessures moyennement graves ou mineures, et/ou des dommages matériels.

 **AVERTISSEMENT**

Lors de l'installation de l'appareil

- Ne pas exposer l'appareil à la pluie et le protéger de tout contact avec de l'eau ou d'autres liquides afin d'éviter un incendie ou une électrocution.
- Utilisez l'appareil uniquement avec la tension spécifiée sur le chargeur. L'utilisation d'une tension supérieure à celle spécifiée peut être à l'origine d'un incendie ou d'une électrocution.
- Ne pas couper, entortiller, modifier ou endommager le cordon d'alimentation. En outre, éviter d'utiliser le cordon d'alimentation à proximité d'un radiateur et ne jamais placer d'objets lourds (y compris l'appareil lui-même) sur le cordon d'alimentation, car ceci présente un risque d'incendie ou d'électrocution.
- Les câbles externes branchés aux bornes marquées de .. ⚡ doivent être installés par un technicien spécialement formé.
- L'appareil doit être branché à une prise d'alimentation avec mise à la terre de protection.

Pendant l'utilisation de l'appareil

- En cas de survenue des irrégularités suivantes pendant l'utilisation, couper immédiatement l'alimentation, débrancher la fiche du cordon d'alimentation de l'adaptateur secteur de la prise secteur et contacter le représentant TOA le plus proche. Ne pas essayer pas d'utiliser l'appareil dans ces conditions sous peine de provoquer un incendie ou une électrocution.

- Détection de fumée ou d'une odeur inhabituelle émanant de l'appareil.
- Pénétration d'eau ou d'un objet métallique dans l'appareil.
- Chute ou endommagement de l'appareil
- Dégradation du cordon d'alimentation (âme du câble dénudée, déconnexion etc.).
- Dysfonctionnement (absence de tonalité).
- Pour empêcher un incendie ou une électrocution, ne jamais ouvrir ni ne retirer le boîtier de l'appareil, en raison de la présence de pièces à haute tension. Toutes les opérations de maintenance, notamment les modifications apportées à l'intérieur de la machine, doivent être réalisées par un technicien qualifié.
- Ne pas placer de tasses, bols ou autres récipients remplis de liquides ou d'objets métalliques au-dessus de l'appareil. S'ils se répandent par accident sur l'appareil, ils peuvent provoquer un incendie ou une électrocution.
- Ne pas insérer ni laisser tomber d'objets métalliques ou de matériaux inflammables dans les événements de ventilation du capot de l'appareil sous peine de provoquer un incendie ou une électrocution.
- Ne pas toucher la fiche du cordon d'alimentation pendant un orage - Risque d'électrocution.

⚠ ATTENTION

<p>Lors de l'installation de l'appareil</p> <ul style="list-style-type: none"> • Ne jamais brancher, ni débrancher la fiche du cordon d'alimentation avec les mains mouillées. Risque d'électrocution. • Pour débrancher le cordon d'alimentation, veiller à le 		<p>par sa fiche; ne jamais tirer directement le cordon. Utiliser l'appareil avec un cordon d'alimentation endommagé peut présenter un risque d'incendie ou d'électrocution.</p> <ul style="list-style-type: none"> • Lors du déplacement de l'appareil, veiller à retirer la
<p>fiche du cordon d'alimentation de l'adaptateur secteur de la prise murale. Si le chargeur est déplacé avec le cordon d'alimentation branché dans la prise, ce dernier risque d'être endommagé, ce qui présente un risque d'incendie ou d'électrocution. Pour retirer le cordon d'alimentation, le tirer par la prise.</p> <ul style="list-style-type: none"> • Éviter d'installer l'appareil dans un endroit humide ou poussiéreux, en plein soleil, à proximité d'un radiateur, ou dans un endroit dégageant de la fumée noire ou de la vapeur sous peine de provoquer un incendie ou une électrocution. • Pour éviter les chocs électriques, veiller à débrancher l'appareil avant de connecter les haut-parleurs. • Cet appareil doit uniquement être monté dans un bâti. Veiller à suivre les instructions ci-dessous lors du montage en bâti. • Risque d'incendie ou de blessure corporelle. • Installer le bâti sur un sol stable. • Le fixer à l'aide de boulons d'ancrage ou d'un autre dispositif pour l'empêcher de tomber. • Lors du montage de l'appareil, veiller à utiliser une vis de plus de 5mm (0,2") de diamètre et de plus de 12mm (0,47") de longueur. • Pour brancher le cordon d'alimentation à une prise CA, vérifier l'intensité maximale de l'appareil. <p>Pendant l'utilisation de l'appareil</p> <ul style="list-style-type: none"> • Mettre toutes les commandes du niveau sortie en position 0 avant que l'alimentation ne soit restituée. Si 		<p>l'appareil est mis sous tension alors que ces commandes ne sont pas en position 0, un bruit fort au point de dégrader l'audition risque d'être émis.</p> <ul style="list-style-type: none"> • Ne pas utiliser l'appareil pendant une période prolongée si le son est distordu. Les haut-parleurs branchés risquent de surchauffer et de provoquer un incendie. • Pour nettoyer l'appareil, contacter votre revendeur TOA. L'accumulation de poussière pendant une période prolongée peut entraîner un incendie ou une dégradation de l'appareil. • L'accumulation de poussière sur la fiche du cordon d'alimentation ou dans la prise secteur présente un risque d'incendie. Les nettoyer régulièrement. Par ailleurs, insérer complètement la fiche dans la prise murale. • Par mesure de sécurité, lors du nettoyage ou lorsque l'appareil n'est pas utilisé pendant 10 jours ou plus, couper l'alimentation, et débrancher la fiche du cordon d'alimentation de l'adaptateur secteur de la prise secteur - Risque d'incendie ou d'électrocution. <p> L'éclair accompagné d'un symbole représentant une pointe de flèche à l'intérieur d'un triangle équilatéral avertit l'utilisateur de la présence d'une "tension dangereuse" à l'intérieur de l'enceinte d'un téléviseur, dont la magnitude peut être suffisante pour constituer un risque de choc électrique pour les personnes</p>

3. GENERAL DESCRIPTION

TOA's MA-725F matrix amplifier and MM-700F is all-in-one solution for multi-channel or multi-zone applications combined 6x4 audio matrix, DSP and 4ch Class-D amplifier (*) into one chassis. It is equipped with 4 independent line inputs, 2 MIC/LINE priority inputs. Each output has independent DSP preset adjustment also comes with input source matrix selection. It features a high power handling (250Wx4 @ 70V/100V) (*) and various inputs capabilities. Its wide range of applications include general or emergency announcement and background music playing at restaurants, pubs, retail stores, schools, offices and etc.

(*) MA-725F only

4. FEATURES

- 4 stereo-summing line inputs with matrix routing to 4 amplifier outputs.
 - Each line input has input level adjustment and assign restriction setting for each output to prevent wrong routing selection.
 - 2 priority MIC/LINE inputs with different priority level for paging or other pre-recorded source can override the selected line input on assigned output channels.
 - Each priority input also has input level, mute sensitivity and mute hold time adjustments.
 - Each output channel is equipped with 250W Class-D amplifier at 70V/100V output voltage selectable with independent DSP preset selection and 50Hz HPF for the protection of connected speakers. (*)
 - Selectable DSP preset selections include general EQs, like Loudness curves, TOA speaker EQs and crossover settings to be used with sub-woofers.
 - Each output channel also has auxiliary line output to deliver the audio to other system.
 - This matrix doesn't need any GUI or network connection for setup at site. (Maintenance purpose only)
 - Optional wall mount remote control, WP-700 can be connected via CAT-5 straight LAN cable to control line input selections and output volume of each output.
-
- Class-D amplifier has a lot of protection features against over current, high temperature and short circuit of speaker lines at each output channel individually. (*)
 - Power supply with Power Factor Correction for reduced power consumption and world-wide operating range. (*)
- (*) MA-725F only

5. HANDLING PRECAUTIONS

- Keep the input cable away from the output cable. If installed close to each other, oscillation could occur.
- To avoid unit failures, never connect outputs of 2 or more channels in parallel.
- Only connect speakers with an impedance equal to or greater than those specified. Connecting speakers with a smaller impedance than specified could cause damage to the unit.
- Install the unit in locations where the temperature is between -10°C and $+40^{\circ}\text{C}$ (14°F and 104°F) and the moisture is less than 90%RH (no dew condensation must be formed).
- To clean, be sure to first turn off this unit's power switch, then wipe with a dry cloth. When the unit gets very dirty, use a cloth damped in a neutral cleanser. Never use benzene, thinner, alcohol, or chemically-treated cleaning cloth because such volatile liquids could deform or discolor the unit.

6. INSTALLATION PRECAUTIONS

CAUTION

Rack mounting screws are not supplied with the unit.
Be sure to use the screws with a diameter of over 5 mm (0.2") and length of over 12 mm (0.47") to mount the unit.
Failure to do so may cause personal injury.

- When mounting the unit in an equipment rack, the inside of the rack must be sufficiently ventilated. To achieve sufficient ventilation, remove all panels on the rear of the rack.
- When mounting the unit in the rack, also mount a Perforated Panel larger than 1U in size (1) at the top and the bottom of the rack, and (2) above and below every 5 units.

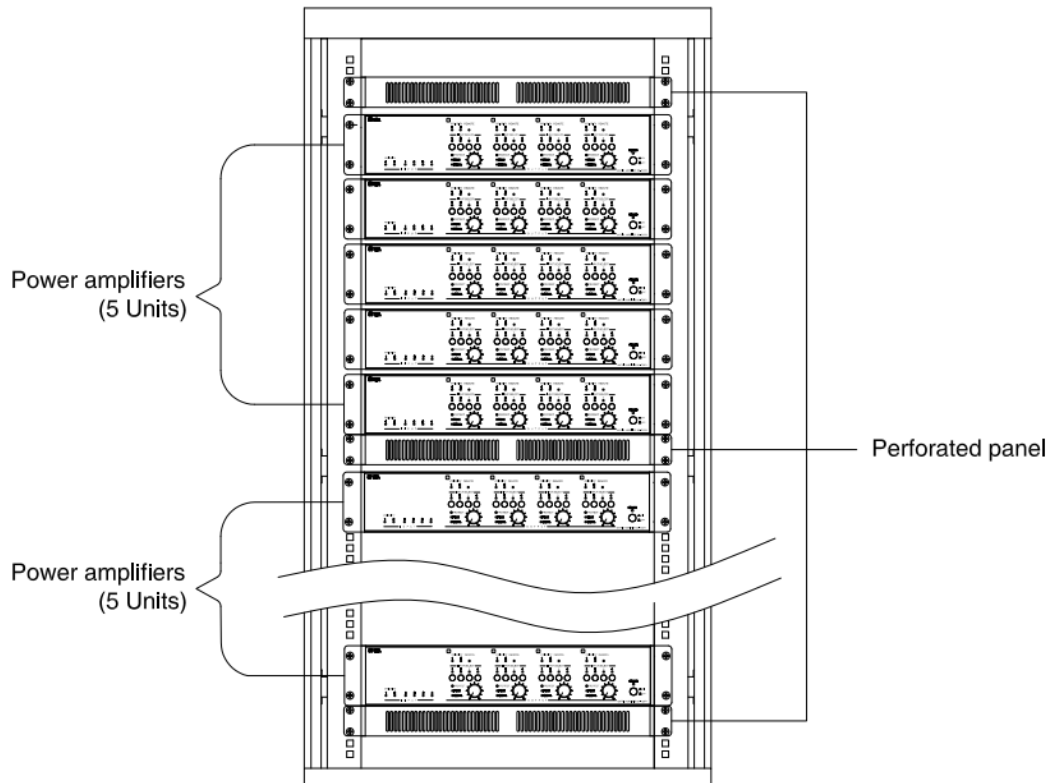

* 1U size = 44.5 mm or 1.75" (reference size)

7. NOMENCLATURE AND FUNCTIONS

[Front]

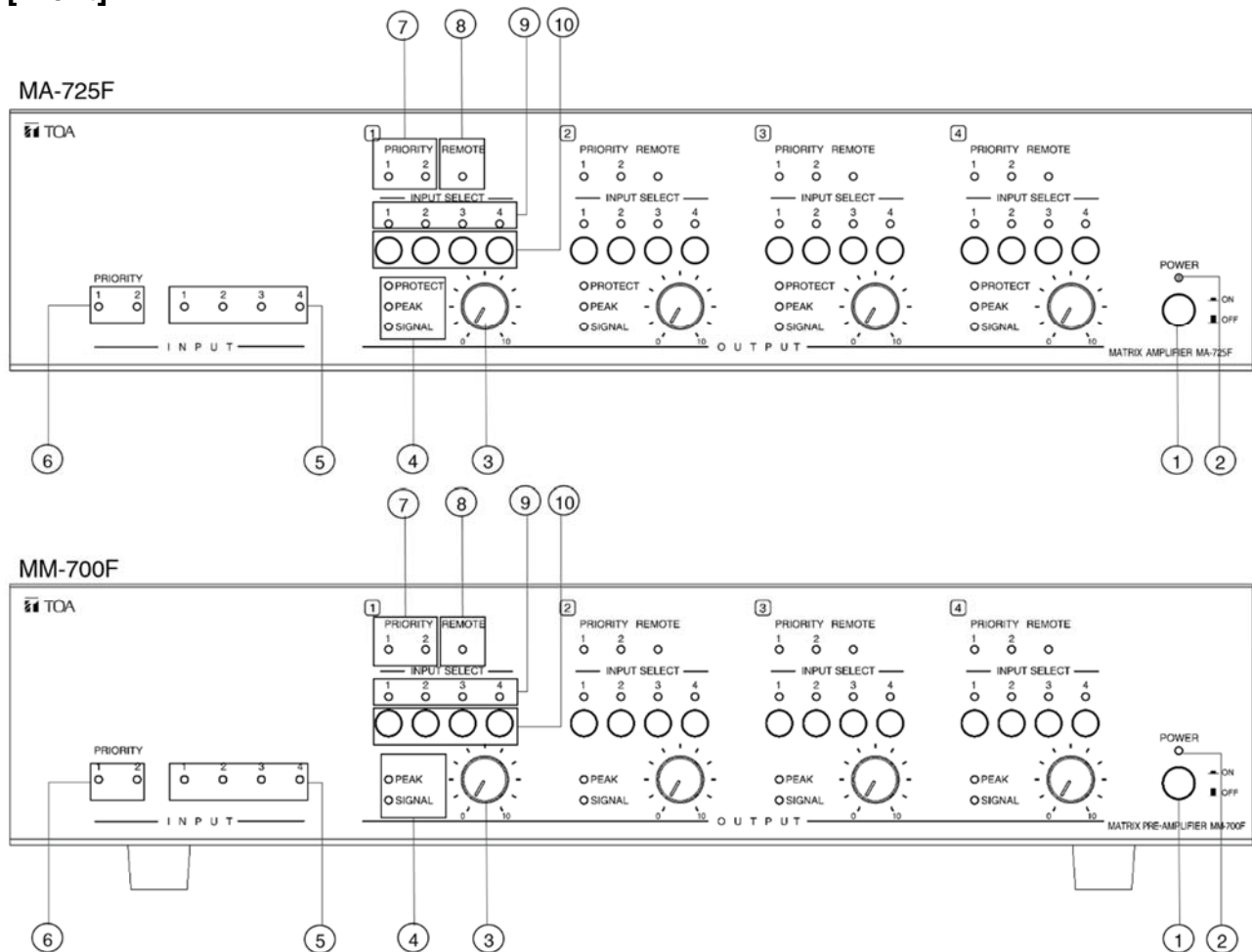

1 POWER SWITCH [ON /OFF]

Press this switch to turn on the amplifier, press the switch again to turn off the amplifier.

2. POWER INDICATOR [POWER] (Blue)

During the power on process the indicator flashes, after amplifier is ready, the indicator lights.

3. CH1 OUTPUT LEVEL CONTROL

Adjust CH1 output level

Note: The functionality of CH2, CH3, CH4 is the same as CH1.

4. CH1 SIGNAL, PEAK, PROTECT INDICATOR (Green, Red, Red)

SIGNAL Indicator: When output level exceeds -36 dBV, the SIGNAL indicator lights.

PEAK Indicator: Lights red when an output signal clips (distortion occurs).

Note: When the Peak indicator lights, turn the output level control (3) counterclockwise until its light extinguishes or decrease the input signal level of the connected external device. Operating the unit while the Peak indicator remains lights may cause the protection circuitry to be activated.

PROTECT Indicator (*): Lights or blinks when the protection circuitry is activated. (See p. 27; Protection Operation List.) When the power is switched on, this indicator lights for about 2 seconds and then extinguishes.

Note: The functionality of CH2, CH3, CH4 is the same as CH1.

5. LINE 1, LINE 2, LINE 3, LINE 4 INPUT SIGNAL INDICATOR (Green)

When LINE 1, LINE 2, LINE 3, LINE 4 input signal is exceed -47dBV, the indicator lights.

6. PRIORITY INPUT SIGNAL INDICATOR [PRIORITY 1, PRIORITY 2] (Green, Green)

PRIORITY INPUT SIGNAL1 Indicator: When the priority input 1 signal (14) exceed -36dBV (line)/-86dBV (mic) the indicator lights.

PRIORITY INPUT SIGNAL2 Indicator: When the priority input 2 signal (14) exceed -36dBV (line)/-86dBV (mic), the indicator lights.

7. CH1 PRIORITY INDICATOR [PRIORITY1, PRIORITY2] (Green, Green)

PRIORITY 1 Indicator: When PRIORITY 1 is activated and assigned to CH1 output, the indicator lights.

PRIORITY 2 Indicator: When PRIORITY 2 is activated and assigned to CH1 output, the indicator lights.

Note: 1. When PRIORITY MIX 1+2 switch is turned on and activated, these two indicator light at the same time.

2. The functionality of CH2, CH3, CH4 is the same as CH1.

8. CH1 PRIORITY INDICATOR [REMOTE] (Yellow)

When remote control panel WP-700 is connected to CH1 of REMOTE TERMINALS, the indicator lights. At this time, both output level and input source selection could be changed by connected WP-700.

Note: 1. When WP-700 is connected, CH1 OUTPUT LEVEL CONTROL (3) and CH1 INPUT SELECT SWITCH (5) on the front panel are defeated and controlled by WP-700.

2. When WP-700 is disconnected, the output level goes back to the setting of CH1 OUTPUT LEVEL CONTROL(3)

3. The functionality of CH2, CH3, CH4 is the same as CH1. **1**

10. CH1 INPUT SELECT SWITCH 1 - 4

Select from LINE 1-4 inputs as the input source for amplifier CH1 output. Select again on the previous selected input turns off the selection of input source.

Note: The functionality of CH2, CH3, CH4 is the same as CH1.**9**

9. CH1 INPUT SELECT INDICATOR [1, 2, 3, 4] (Green)

The led will light with respect to the input select by the INPUT SELECT SWITCH (5) other channel which is not selected will turn off.

Note: The functionality of CH2, CH3, CH4 is the same as CH1.

(*) MA-725F only

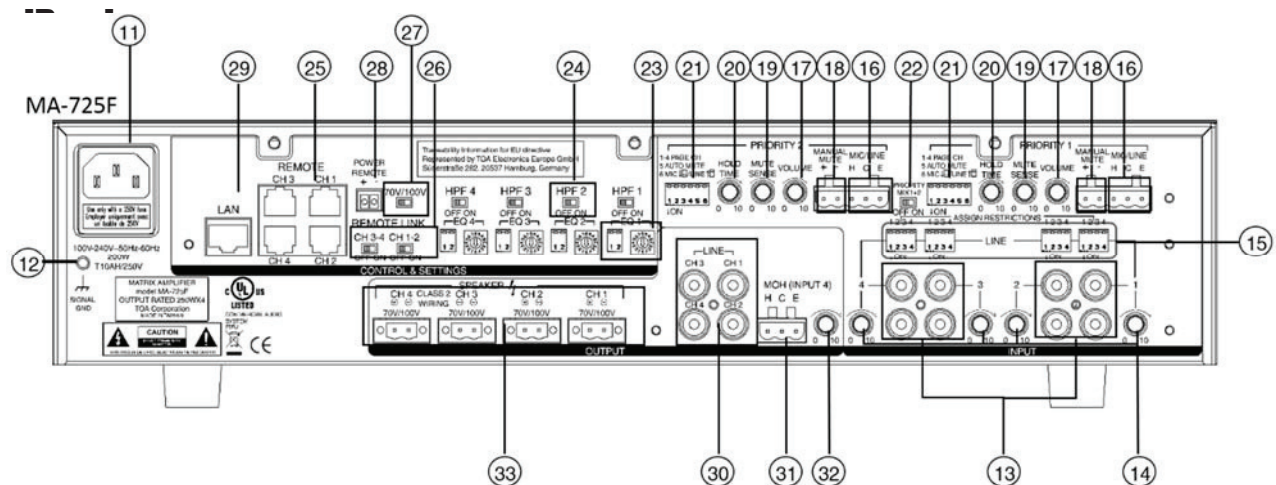

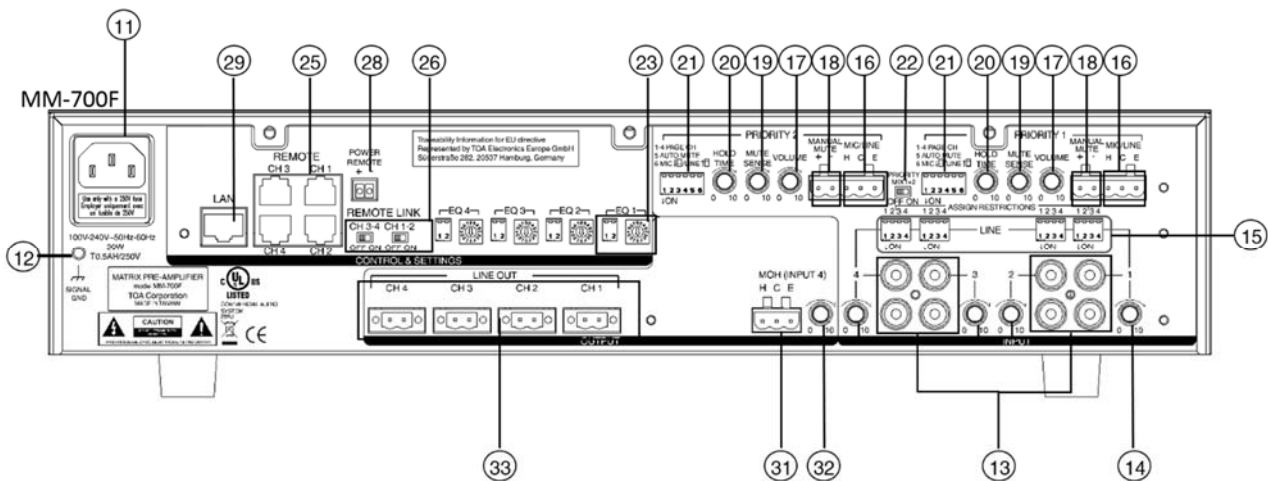

11. AC inlet

Connect the supplied power cord to this inlet. The socket-outlet should be installed near the equipment and the plug (disconnected device) shall be easily accessible.

12. Functional ground terminal [SIGNAL GND]

Hum noise may be generated when external equipment is connected to the unit. Connecting this terminal to the functional ground terminal of the external equipment may reduce the hum noise.

13. LINE 1, LINE 2, LINE 3, LINE 4 INPUT TERMINAL

10 kΩ, -10 dB*, unbalanced RCA Jack (Upper and lower of RCA input signal is mixed)
Connect music source equipment: e.g: CD players.

14. LINE 1, LINE 2, LINE 3, LINE 4 INPUT LEVEL CONTROL

Adjust the input level (sensitivity) of LINE 1, LINE 2, LINE 3, LINE 4.

15. ASSIGNMENT RESTRICTION DIP SWITCHES (LINE 1, LINE 2, LINE 3, LINE 4)

Assign restriction LINE 1, LINE 2, LINE 3, LINE 4 to CH1, CH2, CH3, CH4 outputs.
LINE 1 ASSIGNMENT RESTRICTIONS:

Switch No.	ON	OFF
1	LINE 1 can't be assigned to CH1	LINE 1 can be assigned to CH1
2	LINE 1 can't be assigned to CH2	LINE 1 can be assigned to CH2
3	LINE 1 can't be assigned to CH3	LINE 1 can be assigned to CH3
4	LINE 1 can't be assigned to CH4	LINE 1 can be assigned to CH4

Note: 1) The functionality for LINE 2, LINE 3, LINE4 is the same as LINE 1.

2) When the assignment restriction is set, both INPUT SELECT SWITCH (10) or connected WP-700, are not allowed to select the restricted channel.

16. MIC/LINE input terminal (PRIORITY 1, PRIORITY 2)

MIC: 2.2K, -60 dB*/ LINE: 2.2K, -10 dB*, electronically-balanced inputs of 3-pin removable terminal block type.

Connect microphone or line level music source equipment. MIC/LINE gain could be from the PRIORITY FUNCTIONAL DIP SWITCH (20) #6.

17. MIC/LINE input level control (PRIORITY 1, PRIORITY 2)

Adjust the input level (sensitivity) of the MIC/LINE

18. Manual mute terminal

Open voltage: DC 3.3V, Short current: <5mA

1) When (+), (-) shorted: The selected LINE 1, LINE 2, LINE3, LINE4 input signal to CH1, CH2, CH3, CH4 output will be muted, and switch to the page channel (1st ~4th switch of (20)) that have been assigned by PRIORITY 1, PRIORITY 2 inputs.

2) When (+), (-) opened: CH 1, CH 2, CH 3, CH 4 output will gradually recovered from the previous assigned LINE 1, LINE 2, LINE3, LINE4 signal. The recovery time is controlled by the HOLD TIME control (19).

19. MUTE SENSE control (PRIORITY 1, PRIORITY 2)

Adjust the threshold (sensitivity) of the mute function of the PRIORITY 1, PRIORITY 2 inputs. In other words, if PRIORITY 1, PRIORITY 2 input signal exceed the threshold that set by MUTE SENSE, it will mute the LINE 1, LINE 2, LINE 3, LINE 4 signal to CH1, CH2, CH3, CH4 outputs. Rotate clockwise will raise the sensitivity, counter-clockwise will lower the sensitivity.

20. HOLD TIME control (PRIORITY 1, PRIORITY 2)

Adjust the recovery time of the LINE 1, LINE 2, LINE 3, LINE 4 to CH1, CH2, CH3, CH4 outputs. Rotate clockwise will increase the recovery time (maximum 10sec), counter-clockwise will decrease the recovery time (minimum 50ms)

21. PRIORITY FUNCTIONAL DIP SWITCH (PRIORITY 1, PRIORITY 2)

Control the functionality of the PRIORITY 1 and PRIORITY 2

Switch No.	ON	OFF
1	PRIORITY 1/2 can be switched to CH1 output	PRIORITY 1/2 cannot be switched to CH1 output
2	PRIORITY 1/2 can be switched to CH2 output	PRIORITY 1/2 cannot be switched to CH2 output
3	PRIORITY 1/2 can be switched to CH3 output	PRIORITY 1/2 cannot be switched to CH3 output
4	PRIORITY 1/2 can be switched to CH4 output	PRIORITY 1/2 cannot be switched to CH4 output
5	The mute function is controlled by the PRIORITY 1/2 input signal or manual mute (16)	The mute function is only controlled by the manual mute (16)
6	PRIORITY 1/2 input gain switch to MIC level	PRIORITY 1/2 input gain switch to LINE level

22. PRIORITY MIX1+2 switch

Control the input mode of the PRIORITY 1/2

ON	OFF
PRIORITY 1 and PRIORITY 2 will be mixed and output to CH1, CH2, CH3, CH4 when mute activated. The PRIORITY FUNCTIONAL DIP SWITCH (20), MUTE SENSE control (18), HOLD TIME control (19) will be followed by PRIORITY 1's setting	The PRIORITY 1 has the higher priority level than PRIORITY 2. When There is mute function activated. Unit will output PRIORITY 1's input first.

23. EQ BANKS and PRESETS SELECTION



The 2-bit DIP switch select the bank of respect to the 16 EQ presets. Total 4 banks.



The 4-bit rotary switch selects 16 EQ presets from each banks.

Note: The functionality of CH2, CH3, CH4 is the same as CH1.
Please see page 23, "11.2 EQ preset selections" for more details.

24. HPF SWITCH (*)

Control the activation of HPF (High Pass filter) on outputs.

ON	OFF
The CH1, CH2, CH3, CH4 will has 50Hz, -12dB/oct. high pass filter on output. This is useful to protect the speaker when the transformer of the distribute speaker couldn't handle low frequency.	The output frequency response is flat from 20Hz to 20kHz.

25. REMOTE TERMINALS (CH1, CH2, CH3, CH4 remote controls)

RJ45 connector, use for connecting the remote module WP-700.
After connecting WP-700 could provide the following functionality:
1) Switch the input source LINE 1, LINE 2, LINE 3, LINE 4 to CH1, CH2, CH3, CH4 outputs.
2) Adjust the volume of connected channel.

Note: When the WP-700 is connected, the OUTPUT LEVEL CONTROL (3) on front panel and INPUT SELECT SWITCH (10) won't be functional. It means this two function will follow WP-700 setting. Also, the REMOTE INDICATOR (8) will light.

26. REMOTE LINK SWITCH (CH1-2, CH3-4)

CH1-2:

ON	OFF
CH1, CH2 could control the CH1 and CH2's volume and input selection by one WP-700 at the same time. The REMOTE INDICATOR on CH1 and CH2 will light at the same time. Note: Only connect to CH1's REMOTE TERMINAL to present remote link function	CH1, CH2's volume is controlled separated by two WP-700.

CH3-4:

ON	OFF
CH3, CH4 could control the CH1 and CH2's volume and input selection by one WP-700 at the same time. The REMOTE INDICATOR on CH3 and CH4 will light at the same time. Note: Only connect to CH3's REMOTE TERMINAL to present remote link function	CH3, CH4's volume is controlled separated by two WP-700.

27. 70V/100V OUTPUT MODE SWITCH (*)

Adjust the amplifier output mode

70V	100V
Maximum output will be set to 70Vrms (maximum load impedance = 20ohm)	Maximum output will be set to 100Vrms (maximum load impedance = 40ohm)

28. POWER REMOTE TERMINAL

Open voltage: 3.3V, Shorted current: <1mA

When AC mains is connected to (11) and POWER SWITCH (1) is in ON position, shorted will turn off the power amplifier and all of the indication for power saving. Open will in normal operation.

29. LAN PORT

RJ-45 10/100M Ethernet connection.

Maintenance purpose only for factory.

30. LINE OUTPUT TERMINAL (CH1, CH2, CH3, CH4) (*)

600Ω, 0dB*, RCA connector.

Auxiliary line level output (just before the amplifier input).

31. MOH OUTPUT TERMINAL

600Ω, 0dB*, transformer- isolated balanced output, removable terminal block type.

LINE4 input is assigned to this output.

Note:

1. The MOH output level is not affected by the input level control of the LINE4.
2. MOH output doesn't have MUTE functionality.
3. MOH output doesn't have EQ functionality.

32. MOH OUTPUT INPUT LEVEL CONTROL

Adjust the input level of the MOH OUTPUT.

33. SPEAKER OUTPUT TERMINAL (CH1, CH2, CH3, CH4)

MA-725F:

70V/100V output (select by the 70V/100V OUTPUT MODE SWITCH (26)), removable terminal block type. Connect to speaker.

MM-700F:

600Ω, 0dB*, removable terminal block type. Line level output.

* 0 dB = 1Vrms

(*) MA-725F only

8. CONNECTION EXAMPLES

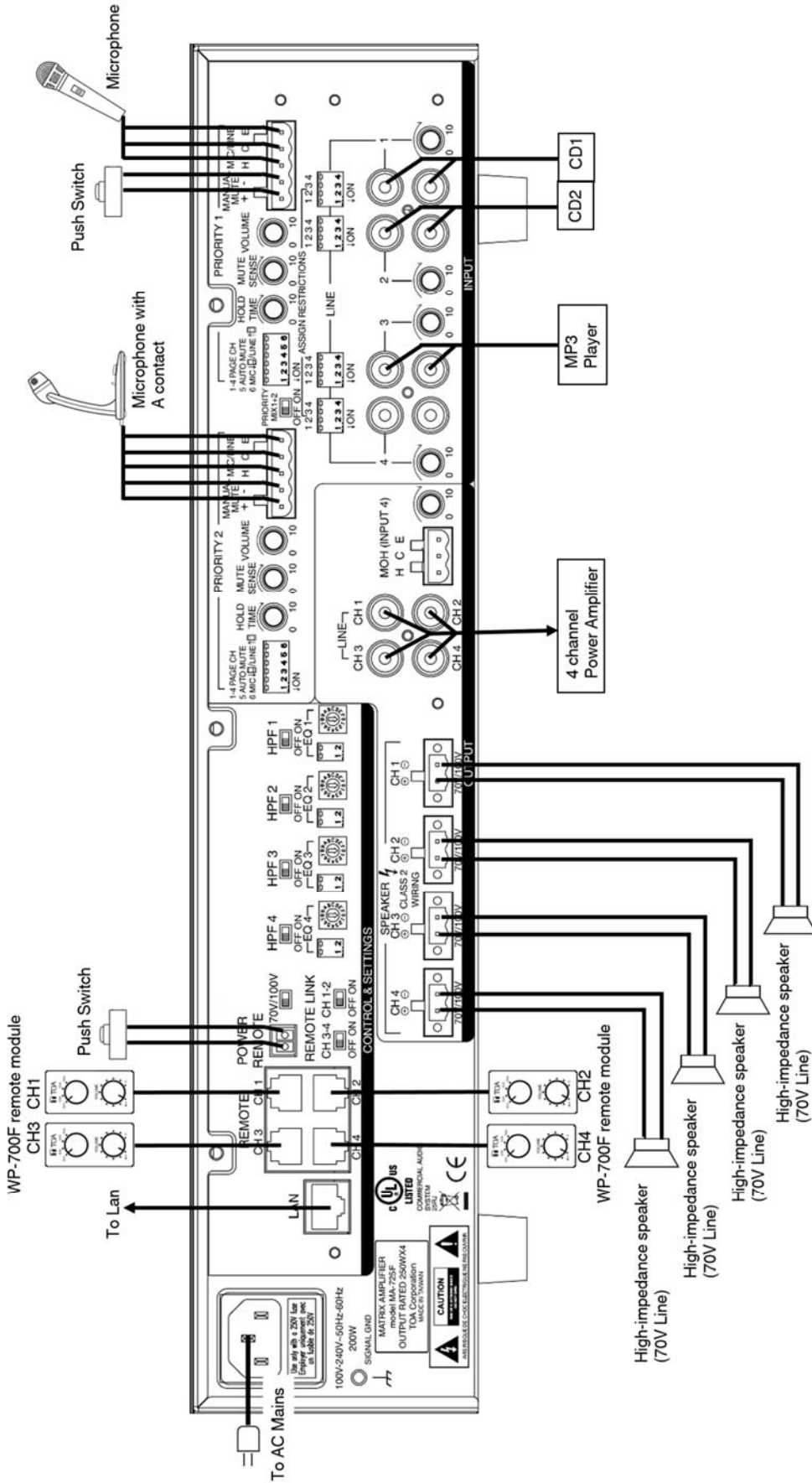

MA-725F

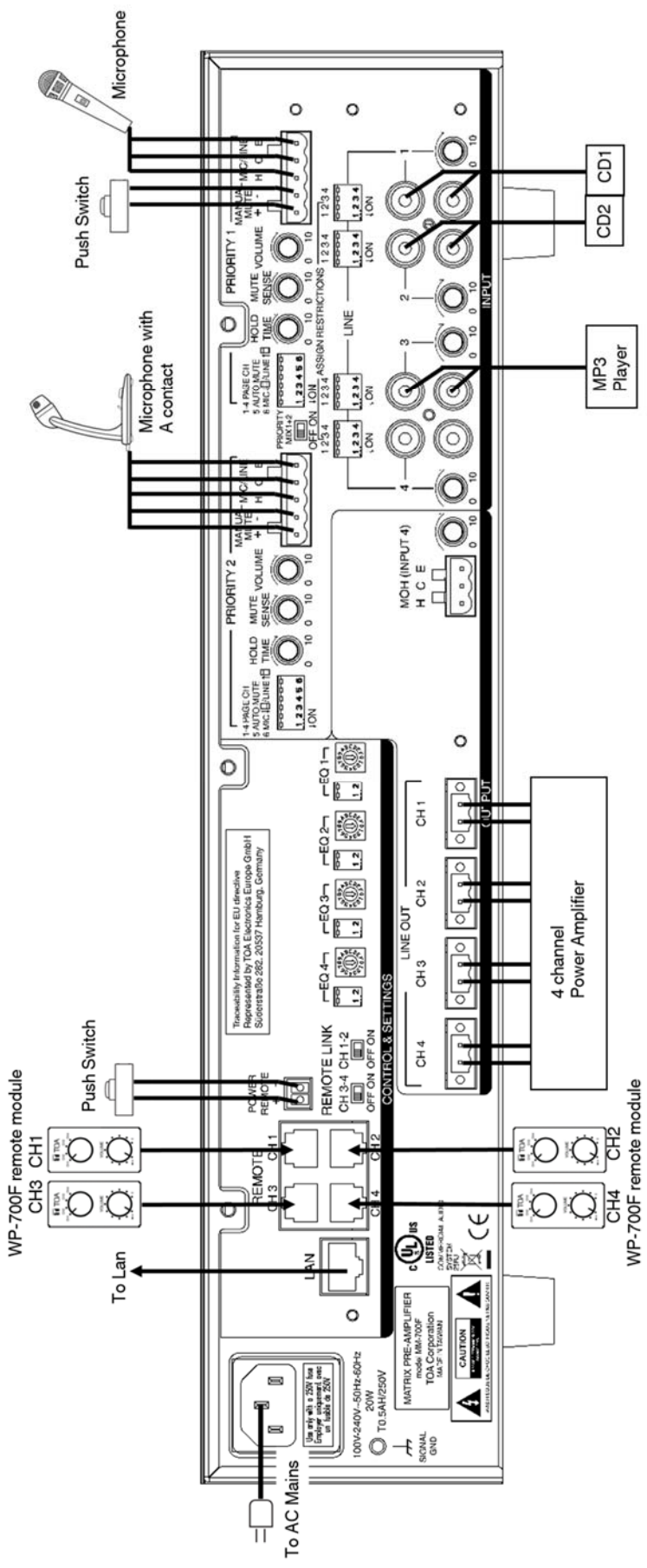

MM-700F

9. CONNECTION

9.1. Removable Terminal Plug Connection

Cautions

- Be sure to use shielded cables for audio signal lines.
- Avoid soldering cable conductor, as contact resistance may increase when the cable is tightened and the solder is crushed, possibly resulting in an excessive rise in joint temperatures.
- Use cables of AWG 12 – 24.

Cable end treatment

Shielded cable

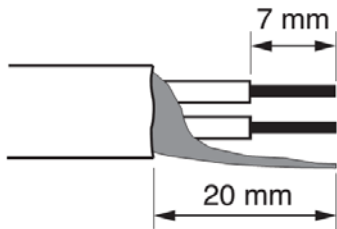

Connector connections

Step 1. Loosen the terminal screw, then insert the cable.

Step 2. Retighten the terminal screw. (Pull on the cable to ensure it is securely connected.)

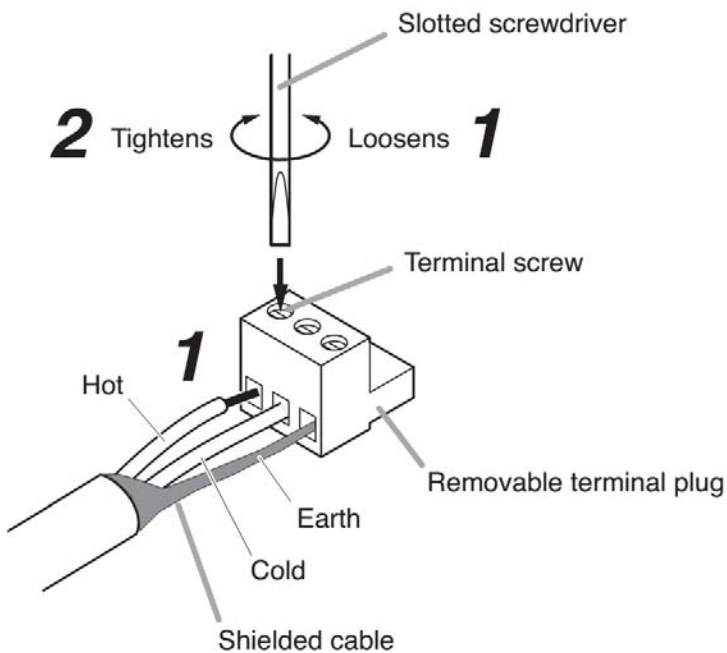

Tip

Recommended slotted screwdriver type: Screwdriver with blade that is 3 mm (0.12") in width.

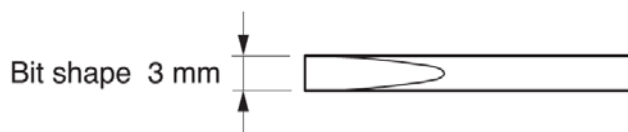

9.2. How to Connect Input Signals

9.2.1. LINE 1, LINE 2, LINE 3, LINE 4 connections

L and R line signals are mixed inside the unit.

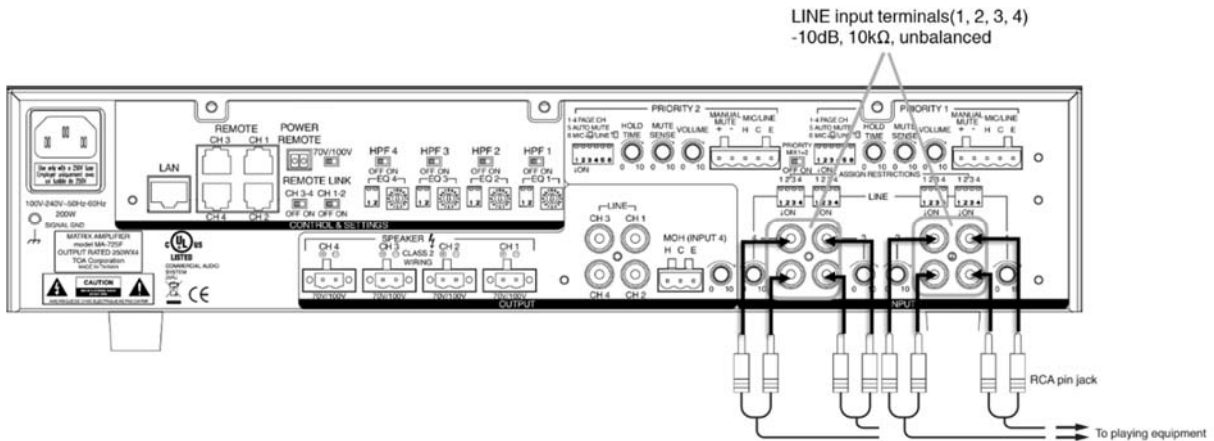

9.2.2. PRIORITY 1 and PRIORITY 2 connections

Use the supplied Small type removable terminal plug (5 pins) for connection. PRIORITY 1 and PRIORITY 2 can be set to MIC or LINE input.

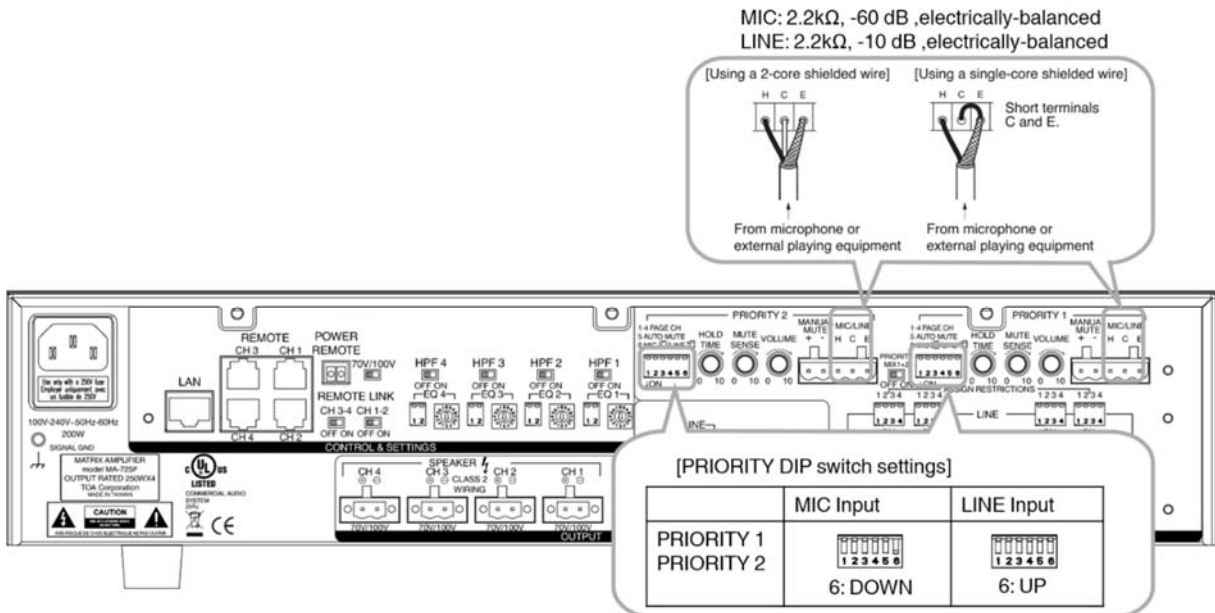

9.3. Speaker Output Connections

The unit can operated at 70V or 100V line high-impedance speakers Class 2 wiring may be used. Using supplied removable terminal plug (2 pins), connect the speaker line to each speaker terminals.

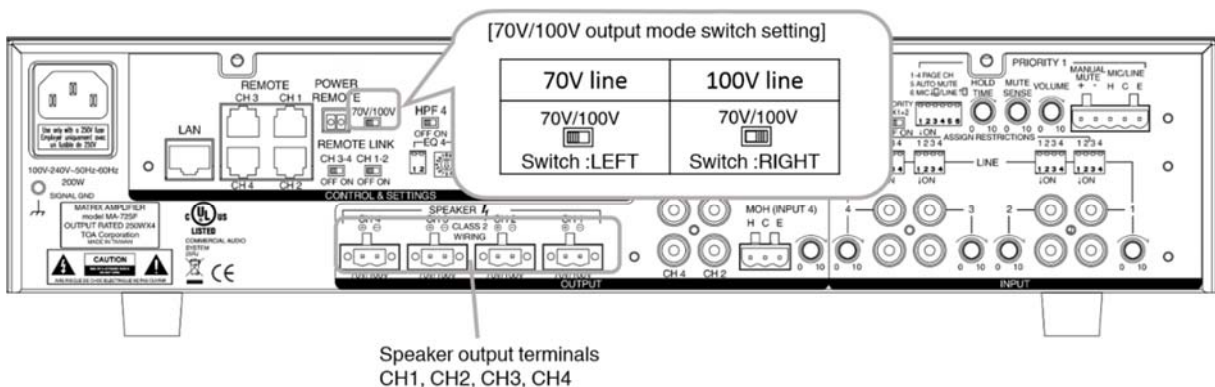

9.3.1. High-impedance 70V line speaker connections (*)

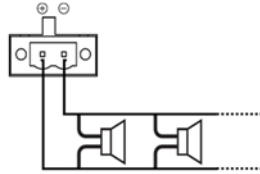

Total wattage: 250W or less
Total impedance: 20Ω or more

9.3.2. High-impedance 100V line speaker connections (*)

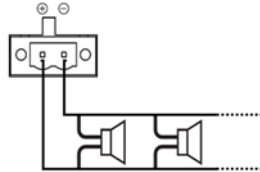

Total wattage: 250W or less
Total impedance: 40Ω or more

9.4. MOH Output Connections

Use the supplied removable terminal plug (3 pins) for connection.

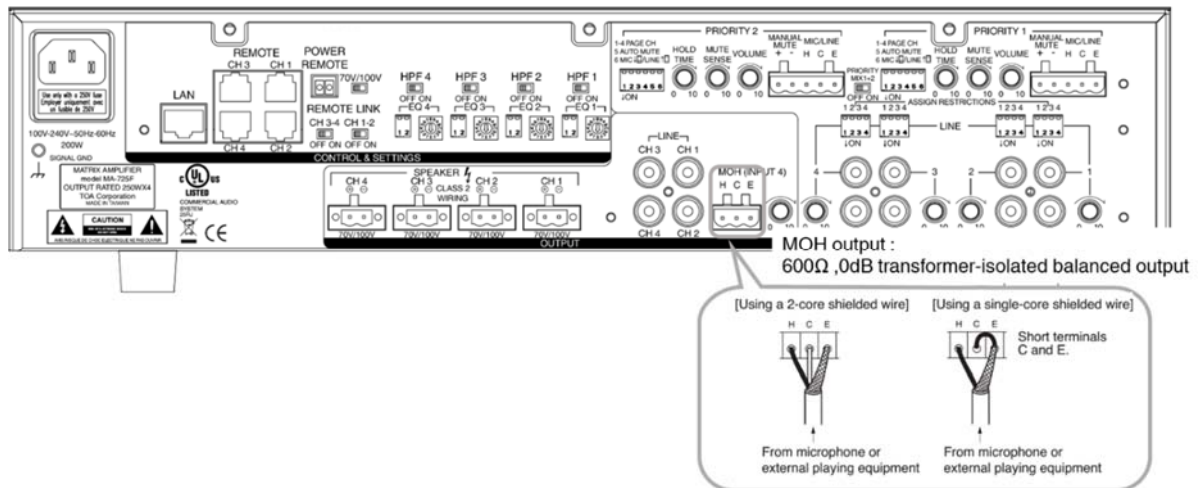

9.5. LINE output connections

Auxiliary line level output for zone expansion.

LINE output :
600Ω ,0 dB, unbalanced output

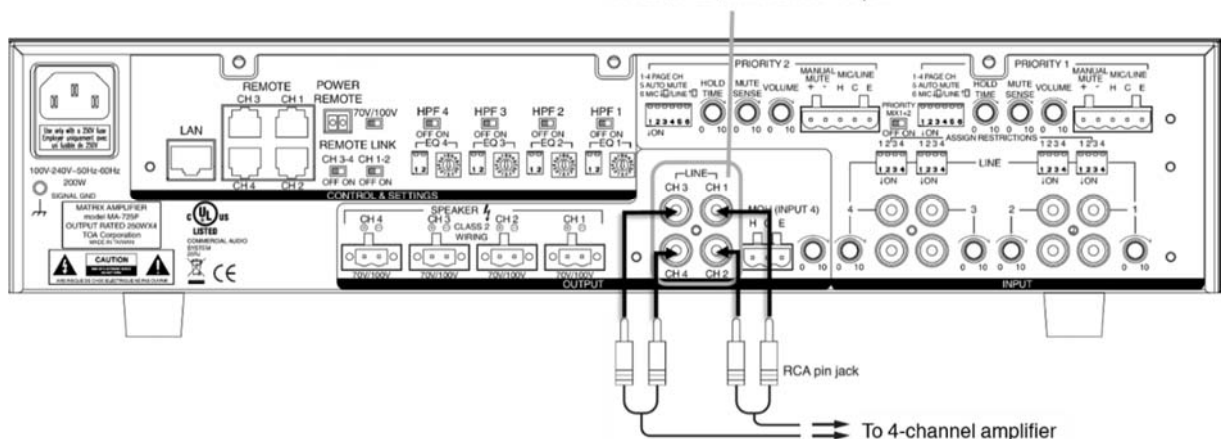

9.6. Remote Control Equipment Connections

9.6.1. Manual muting terminal connections

If a no-voltage contact is connected, closing the contact allows the pre-determined input channel volume to be reduced by a preset level of attenuation.

If a microphone with a contact is connected as shown in Connection (p. 12), the audio of other channels will be muted for as long as the microphone's talk switch is pressed.

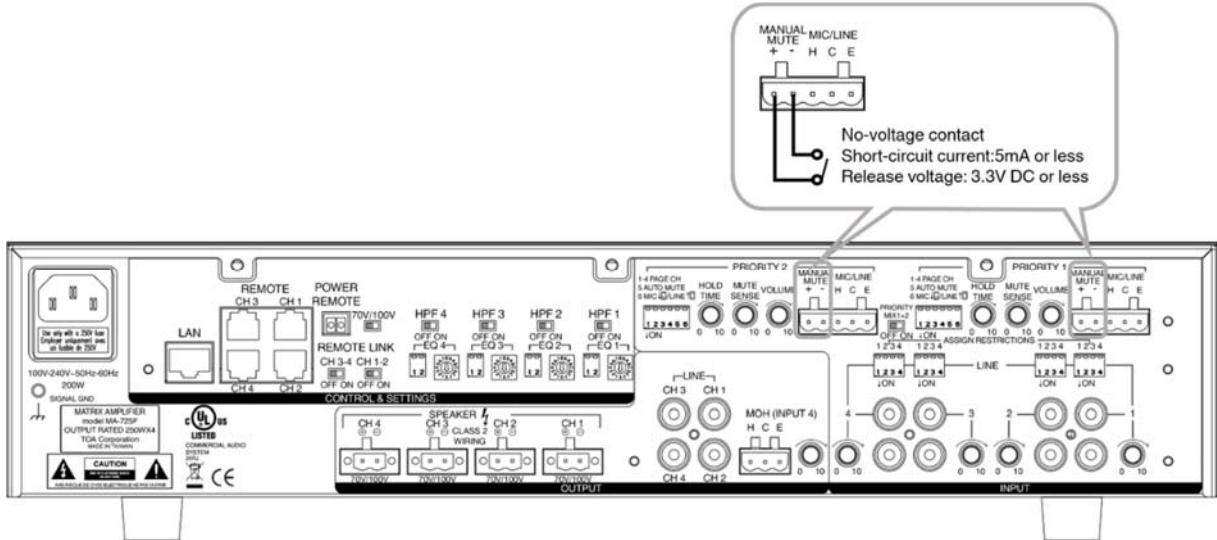

9.6.2. Power remote terminal connections

If a no-voltage contact is connected, closing the contact allows the amplifier goes into power saving mode. All of the indication will be turn off.

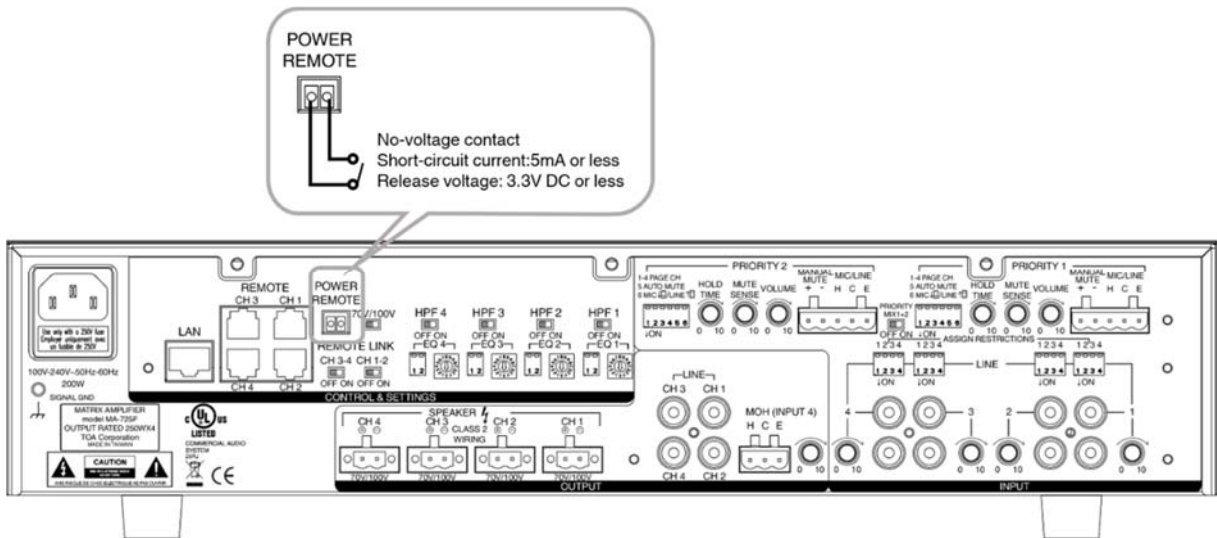

9.6.3. Remote terminals (RJ-45) connections

Each channel's volume and input selection could be remotely adjusted by WP-700 remote module.

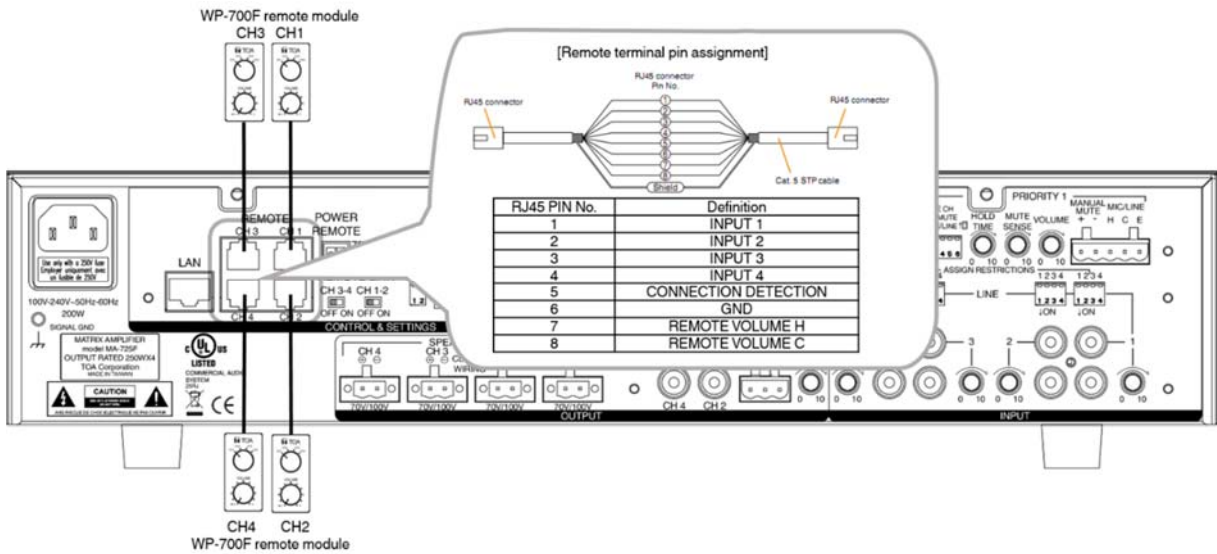

(*) MA-725F only

10. MUTING FUNCTIONS

The unit's priority/mute (paging) functions is to mute the LINE 1, LINE 2, LINE 3, LINE 4 signal that routed to CH1, CH2, CH3, CH4's outputs and then route PRIORITY 1 or PRIORITY 2 signals to outputs. The priority level of each inputs is as following:

Priority level	PRIORITY MIX1+2 : OFF	PRIORITY MIX1+2 :ON
HIGHER	PRIORITY 1	PRIORITY 1/ PRIORITY 2
↑	PRIORITY 2	
LOWER	LINE1, LINE2, LINE3, LINE4	LINE1, LINE2, LINE3, LINE4

10.1 Manual Mute

Step 1. Assign the PAGE CH:



Assign paging channel from the PRIORITY FUNCTIONAL DIP SWITCH.

Switch No.	ON: DOWN	OFF: UP
1	PRIORITY 1/2 can be switched to CH1 output	PRIORITY 1/2 cannot be switched to CH1 output
2	PRIORITY 1/2 can be switched to CH2 output	PRIORITY 1/2 cannot be switched to CH2 output
3	PRIORITY 1/2 can be switched to CH3 output	PRIORITY 1/2 cannot be switched to CH3 output
4	PRIORITY 1/2 can be switched to CH4 output	PRIORITY 1/2 cannot be switched to CH4 output

Step 2. Shorting the manual mute terminal (+), (-):

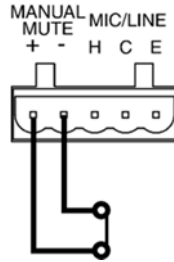

When shorting manual mute terminal (+), (-): the LINE 1, LINE 2, LINE 3, LINE 4 signal that have been routed to assigned page channel CH1, CH2, CH3, CH4's outputs will be muted, and route PRIORITY 1 or PRIORITY 2 signals to outputs.

Step 3. Release the manual mute terminal (+), (-):

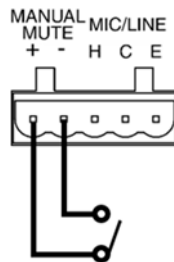

When opening manual mute terminal (+), (-): The LINE 1, LINE 2, LINE 3, LINE 4 will gradually route back to CH1, CH2, CH3, CH4 output. The time that the route back signal starting to fade in is control by the HOLD TIME control.

10.2 Auto Mute

Step 1. Set the AUTO MUTE switch ON:



Switch No.	ON: DOWN	OFF: UP
5	The mute function is controlled by the PRIORITY 1/2 input signal or manual mute	The mute function is only controlled by the manual mute

Step 2. Assign the PAGE CH:

This operation is same as 10.1 Step 1.

Step 3. Set PRIORITY 1 or PRIORITY 2 auto mute trigger threshold:

Adjust the MUTE SENSE CONTROL to set the auto mute trigger threshold, rotate clockwise will increase the sensitivity, rotate counter-clockwise will decrease the sensitivity.

Step 4. PRIORITY 1 or PRIORITY 2 signal trigger the Auto Mute:

When the PRIORITY 1 or PRIORITY 2 signal level exceeds the mute trigger threshold, the LINE 1, LINE 2, LINE 3, LINE 4 to assigned page channel's output will be mute and route PRIORITY 1 or PRIORITY 2 signal to output.

Step 5. Release Mute

When the PRIORITY 1 or PRIORITY 2 signal level is below than the mute trigger threshold, depends on the setting of the HOLD TIME CONTROL, the signal will start to fade in after the hold time interval is time out.

10.3 Priority Mix

Step 1. Set the PRIORITY MIX 1+2 switch on



ON (Right)	OFF (Left)
PRIORITY 1 and PRIORITY 2 will be mixed and output to CH1, CH2, CH3, CH4 when mute activated. The PRIORITY FUNCTIONAL DIP SWITCH (20), MUTE SENSE control (18), HOLD TIME control (19) will be followed by PRIORITY 1's setting	The PRIORITY 1 has the higher priority level than PRIORITY 2. When There is mute function activated. Unit will output PRIORITY 1's input first.

Step 2. Assign the PAGE CH:

This operation is same as 10.1 Step 1.

Note: When PRIORITY MIX 1+2 is on, the paging channel only need to set from Priority 1's PRIORITY FUNCTIONAL DIP SWITCH, set from Priority 2's PRIORITY FUNCTIONAL DIP SWITCH won't affect the setting.

Step 3. Set PRIORITY 1+2 auto mute trigger threshold:

Adjust the MUTE SENSE CONTROL to set the auto mute trigger threshold, rotate clockwise will increase the sensitivity, rotate counter-clockwise will decrease the sensitivity.

Note: When PRIORITY MIX 1+2 is on, the auto mute trigger threshold is control only from on Priority 1's MUTE SENSE CONTROL, adjust from Priority 2's MUTE SENSE CONTROL won't affect the setting.

Step 4. PRIORITY 1+2 signal trigger the Auto Mute:

When the PRIORITY 1 + PRIORITY 2 signal level exceeds the mute trigger threshold, the LINE 1, LINE 2, LINE 3, LINE 4 to assigned page channel's output will be mute and route PRIORITY 1 + PRIORITY 2 signal to output.

Step 5. Release Mute

When the PRIORITY 1 + PRIORITY 2 signal level is below than the mute trigger threshold, depends on the setting of the HOLD TIME CONTROL, the signal will start to fade in after the hold time interval is time out.

Note: When PRIORITY MIX 1+2 is on, the hold time is control only from on Priority 1's HOLD TIME CONTROL, adjust from Priority 2's HOLD TIME CONTROL won't affect the setting.

11. OPERATION

11.1 Input Selection Function

Use the INPUT SELECT SWITCH on the front panel or connect the WP-700 remote module to REMOTE TERMINAL to select the LINE 1, LINE 2, LINE 3, LINE 4 signal source to CH1, CH2, CH3, CH4 outputs.

11.1.1 INPUT SELECT SWITCH [Front]

Step 1. Connect different music source (CD players, mp3 players, tape recorders...) to LINE 1, LINE 2, LINE 3, LINE 4 respectively.

Step 2. Push INPUT SELECT SWITCH on each output channel (CH1, CH2, CH3, CH4) to route LINE in signal to outputs. Push the selected LINE source again can cancel the routing (mute).

Note. Use the ASSIGNMENT RESTRICTION DIP SWITCH to prevent the unwanted source to be selected to the output.

11.1.2 INPUT SELECT SWITCH [Rear using WP-700]

Step 1. Connect different music source (CD players, mp3 players, tape recorders...) to LINE 1, LINE 2, LINE 3, LINE 4 respectively.

Step 2. Connect the WP-700 to the REMOTE TERMINALS

Step 3. Use the WP-700 to control the volume and the input source.

Note. 1. When the WP-700 is connected, the front panel's INPUT SELECT SWITCH and LEVEL CONTROL is not accessible

2. When select to the prohibited channel that set by ASSIGNMENT RESTRICTION DIP SWITCH, the selection is not affective.

11.2 EQ preset selections

Each amplifier output channel has 4-banks by 16 EQ presets (total 64 presets) to compensate or enhance the speaker's frequency response.

Step 1. Select Bank by adjusting the 2-bit BANK DIP SWITCH

Step 2. Rotate the 4-bit PRESET SWITCH to change the EQ preset.

EQ preset lists:

Bank1:

	Preset 1				Preset 2				Preset 3			
	Filter	Gain(dB)	Freq(Hz)	Q	Filter	Gain(dB)	Freq(Hz)	Q	Filter	Gain(dB)	Freq(Hz)	Q
	Flat				Loudness 1				Loudness 2			
EQ1	OFF				OFF				OFF			
EQ2	OFF				OFF				OFF			
EQ3	OFF				OFF				OFF			
EQ4	OFF				OFF				OFF			
EQ5	OFF				PEQ	1	32	0.2	PEQ	2	32	0.2
EQ6	OFF				PEQ	-1	500	1.8	PEQ	-1	500	1.8
EQ7	OFF				PEQ	-1	4k	2.6	PEQ	-2	4k	2.6
EQ8	OFF				PEQ	1	8k	2.6	PEQ	2	8k	2.6
	Preset 4				Preset 5				Preset 6			
	Loudness 3				Bass Boost 1				Bass Boost 2			
	Filter	Gain(dB)	Freq(Hz)	Q	Filter	Gain(dB)	Freq(Hz)	Q	Filter	Gain(dB)	Freq(Hz)	Q
EQ1	OFF				OFF				OFF			
EQ2	OFF				OFF				OFF			
EQ3	OFF				OFF				OFF			
EQ4	OFF				OFF				OFF			
EQ5	PEQ	3	32	0.2	LSHELTV	1	100	1	LSHELTV	2	100	1
EQ6	PEQ	-2	500	1.8	OFF				OFF			
EQ7	PEQ	-2	4k	2.6	OFF				OFF			
EQ8	PEQ	3	8k	2.6	OFF				OFF			
	Preset 7				Preset 8				Preset 9			
	Bass Boost 3				High Cut 1				High Cut 2			
	Filter	Gain(dB)	Freq(Hz)	Q	Filter	Gain(dB)	Freq(Hz)	Q	Filter	Gain(dB)	Freq(Hz)	Q
EQ1	OFF				OFF				OFF			
EQ2	OFF				OFF				OFF			
EQ3	OFF				OFF				OFF			
EQ4	OFF				OFF				OFF			
EQ5	LSHELTV	3	100	1	HSHELTV	-1	15K	1	HSHELTV	-3	15K	1
EQ6	OFF				OFF				OFF			
EQ7	OFF				OFF				OFF			
EQ8	OFF				OFF				OFF			
	Preset 10				Preset 11				Preset 12			
	High Cut 3				Subwoofer LPF/HPF 1				Subwoofer LPF/HPF 2			
	Filter	Gain(dB)	Freq(Hz)	Q	Filter	Gain(dB)	Freq(Hz)	Q	Filter	Gain(dB)	Freq(Hz)	Q
EQ1	OFF				OFF				OFF			
EQ2	OFF				OFF				OFF			
EQ3	OFF				OFF				OFF			
EQ4	OFF				OFF				OFF			
EQ5	HSHELTV	-6	15k	1	LPF	0	120	0.7	LPF	0	110	0.5
EQ6	OFF				OFF				OFF			
EQ7	OFF				OFF				OFF			
EQ8	OFF				OFF				OFF			

Preset 13					Preset 14				Preset 15			
Subwoofer LPF/HPF 3					Full Range with subwoofer 1				Full Range with subwoofer 2			
	Filter	Gain(dB)	Freq(Hz)	Q	Filter	Gain(dB)	Freq(Hz)	Q	Filter	Gain(dB)	Freq(Hz)	Q
EQ1	OFF				OFF				OFF			
EQ2	OFF				OFF				OFF			
EQ3	OFF				OFF				OFF			
EQ4	OFF				OFF				OFF			
EQ5	LPF	0	95	0.7	HPF	0	100	0.7	HPF	0	60	0.4
EQ6	OFF				HPF	0	100	0.7	HPF	0	90	0.6
EQ7	OFF				OFF				OFF			
EQ8	OFF				OFF				OFF			

Preset 16				
Full Range with subwoofer 3				
	Filter	Gain(dB)	Freq(Hz)	Q
EQ1	OFF			
EQ2	OFF			
EQ3	OFF			
EQ4	OFF			
EQ5	LPF	0	80	0.7
EQ6	OFF	0	80	0.7
EQ7	OFF			
EQ8	OFF			

Bank2:

Preset 1					Preset 2				Preset 3			
Flat					F-122				F-122 Lowcut			
	Filter	Gain(dB)	Freq(Hz)	Q	Filter	Gain(dB)	Freq(Hz)	Q	Filter	Gain(dB)	Freq(Hz)	Q
EQ1	OFF				HPF	0	38	0.5	HPF	0	45	0.5
EQ2	OFF				HPF	0	38	0.7	HPF	0	45	0.7
EQ3	OFF				LPF	0	20k	0.7	LPF	0	20k	0.7
EQ4	OFF				OFF				OFF			
EQ5	OFF				PEQ	12	85	2.8	PEQ	7	80	2.8
EQ6	OFF				PEQ	-3	212	0.6	PEQ	-5	180	0.6
EQ7	OFF				PEQ	-8	900	2.8	PEQ	-8	900	2.8
EQ8	OFF				PEQ	8	10k	0.2	PEQ	8	11.2k	0.2

Preset 4					Preset 5				Preset 6			
SW for F-122					SR-S4				HX-5			
	Filter	Gain(dB)	Freq(Hz)	Q	Filter	Gain(dB)	Freq(Hz)	Q	Filter	Gain(dB)	Freq(Hz)	Q
EQ1	OFF				OFF				OFF			
EQ2	OFF				OFF				OFF			
EQ3	OFF				OFF				OFF			
EQ4	OFF				OFF				HPF	0	60	2.0
EQ5	LPF	0	100	0.7	HPF	0	60	1.2	PEQ	2	65	1.4
EQ6	PEQ	3	112	0.6	PEQ	5	16k	1.4	PEQ	-3	800	0.7
EQ7	OFF				OFF				PEQ	-4	2.5k	3.0
EQ8	OFF				OFF				PEQ	5	5k	0.3

Preset 7					Preset 8				Preset 9			
HX-5 Low cut					FB-120				F-1522			
	Filter	Gain(dB)	Freq(Hz)	Q	Filter	Gain(dB)	Freq(Hz)	Q	Filter	Gain(dB)	Freq(Hz)	Q
EQ1	OFF				OFF				HPF	0	50	0.5
EQ2	OFF				OFF				LPF	0	20k	0.7
EQ3	OFF				OFF				PEQ	5	80	1.4
EQ4	OFF				OFF				PEQ	4	8k	1
EQ5	HPF	0	90	1.3	HPF	0	40	2.0	PEQ	-4	206	2.9
EQ6	PEQ	-3	800	0.6	LPF	0	100	1.0	PEQ	-3	690	4.1
EQ7	PEQ	-4	2.5k	2.9	OFF				PEQ	-3	1.4k	3
EQ8	PEQ	5	5k	0.3	OFF				PEQ	-6	2.18k	2.4

Preset 10					Preset 11				Preset 12			
FB-2322					FB-2352				FB-2852			
	Filter	Gain(dB)	Freq(Hz)	Q	Filter	Gain(dB)	Freq(Hz)	Q	Filter	Gain(dB)	Freq(Hz)	Q
EQ1	HPF	0	28	0.5	HPF	0	30	0.7	HPF	0	30	0.7
EQ2	LPF	0	20k	0.7	PEQ	6	80	2.2	PEQ	6	80	2
EQ3	PEQ	8	85	2.2	PEQ	-4	195	2.9	PEQ	-3	125	3.1
EQ4	PEQ	-4	200	2.9	PEQ	-3	850	2.9	PEQ	-6	206	3.1
EQ5	PEQ	-7	900	2.2	PEQ	7	6k	1	PEQ	-2	900	4.3
EQ6	PEQ	-4	3k	1.4	PEQ	-2	2.18k	2.9	PEQ	-4	1.7k	0.6
EQ7	PEQ	7.5	6.7k	0.5	PEQ	-4	7.5k	4.9	PEQ	8	7.3k	0.5
EQ8	PEQ	-4	7.5k	4.9	LPF	0	20k	0.7	LPF	0	20k	0.7

Preset 13					Preset 14				Preset 15			
SR-H2S					SR-H3S				HS-1200			
	Filter	Gain(dB)	Freq(Hz)	Q	Filter	Gain(dB)	Freq(Hz)	Q	Filter	Gain(dB)	Freq(Hz)	Q
EQ1	HPF	0	20	0.5	HPF	0	20	0.5	HPF	0	50	1.4
EQ2	OFF				OFF				PEQ	-5	520	1.4
EQ3	OFF				OFF				OFF			
EQ4	OFF				OFF				OFF			
EQ5	PEQ	7	100	1	PEQ	7	100	1	PEQ	-4	1.6k	5.8
EQ6	PEQ	-7	250	1.4	PEQ	-7	250	1.4	PEQ	-3	2.1k	5.8
EQ7	PEQ	-3	3k	1	PEQ	-6	3k	1	PEQ	-2	5k	1
EQ8	PEQ	4	8k	1	PEQ	2	8k	1	PEQ	3	14k	1.2

Preset 16				
HS-1500				
	Filter	Gain(dB)	Freq(Hz)	Q
EQ1	HPF	0	50	0.7
EQ2	PEQ	-5	530	2.1
EQ3	OFF			
EQ4	OFF			
EQ5	PEQ	-4	1.3k	2.9
EQ6	PEQ	-3	2.1k	2.9
EQ7	PEQ	-2	4.5k	1
EQ8	PEQ	2	14k	0.7

Bank3:

Preset 1					Preset 2				Preset 3			
Flat					Acoustic				Bass Booster			
	Filter	Gain(dB)	Freq(Hz)	Q	Filter	Gain(dB)	Freq(Hz)	Q	Filter	Gain(dB)	Freq(Hz)	Q
EQ1	OFF				LSHELV	2.7	100	1	PEQ	4	48	0.6
EQ2	OFF				PEQ	1	500	2.9	PEQ	3	200	0.7
EQ3	OFF				PEQ	1.5	5k	0.4	HSHELV	-3.1	400	1
EQ4	OFF				OFF				OFF			
EQ5	OFF				OFF				OFF			
EQ6	OFF				OFF				OFF			
EQ7	OFF				OFF				OFF			
EQ8	OFF				OFF				OFF			
Preset 4					Preset 5				Preset 6			
Bass Reducer					Classical				Dance			
	Filter	Gain(dB)	Freq(Hz)	Q	Filter	Gain(dB)	Freq(Hz)	Q	Filter	Gain(dB)	Freq(Hz)	Q
EQ1	LSHELV	-4.5	100	1	PEQ	3	20	0.4	PEQ	3.1	90	0.9
EQ2	HSHELV	2.5	500	1	PEQ	-2.5	200	0.4	PEQ	-0.5	400	0.7
EQ3	OFF				PEQ	-1.6	2k	0.5	PEQ	2.7	2k	0.8
EQ4	OFF				PEQ	1.5	20k	0.4	PEQ	2.7	5k	1.5
EQ5	OFF				OFF				OFF			
EQ6	OFF				OFF				OFF			
EQ7	OFF				OFF				OFF			
EQ8	OFF				OFF				OFF			
Preset 7					Preset 8				Preset 9			
Deep					Electronic				Hip Hop			
	Filter	Gain(dB)	Freq(Hz)	Q	Filter	Gain(dB)	Freq(Hz)	Q	Filter	Gain(dB)	Freq(Hz)	Q
EQ1	PEQ	3.1	20	0.3	HSHELV	3.1	5k	1	LSHELV	4	200	1
EQ2	PEQ	-3.1	300	1	LSHELV	3.1	100	1	PEQ	-6.1	800	0.6
EQ3	PEQ	1.1	1.5k	1	PEQ	-3.6	500	2.9	HSHELV	1	3.01k	1
EQ4	PEQ	-6.1	20k	0.4	OFF				HSHELV	3.1	10k	1
EQ5	OFF				OFF				OFF			
EQ6	OFF				OFF				OFF			
EQ7	OFF				OFF				OFF			
EQ8	OFF				OFF				OFF			
Preset 10					Preset 11				Preset 12			
Jazz					Latin				Lounge			
	Filter	Gain(dB)	Freq(Hz)	Q	Filter	Gain(dB)	Freq(Hz)	Q	Filter	Gain(dB)	Freq(Hz)	Q
EQ1	LSHELV	-1.1	100	1	PEQ	3	20	0.6	PEQ	-1.1	200	1
EQ2	PEQ	-2	1.2k	0.8	PEQ	-3.6	1.2k	0.3	PEQ	3	600	2
EQ3	PEQ	3.1	15.1k	0.4	PEQ	3	20k	0.4	PEQ	-3.1	4k	2.4
EQ4	OFF				OFF				PEQ	1.5	1.2k	2.2
EQ5	OFF				OFF				OFF			
EQ6	OFF				OFF				OFF			
EQ7	OFF				OFF				OFF			
EQ8	OFF				OFF				OFF			
Preset 13					Preset 14				Preset 15			
Piano					Pop				R&B			
	Filter	Gain(dB)	Freq(Hz)	Q	Filter	Gain(dB)	Freq(Hz)	Q	Filter	Gain(dB)	Freq(Hz)	Q
EQ1	PEQ	-1.6	125	1.4	PEQ	6	600	0.4	PEQ	-2	20	1
EQ2	PEQ	0.7	400	2.1	OFF				PEQ	4	90	0.9
EQ3	PEQ	1.5	2k	1.8	OFF				PEQ	-5	600	0.6
EQ4	PEQ	-2.5	20k	0.4	OFF				OFF			
EQ5	OFF				OFF				OFF			
EQ6	OFF				OFF				OFF			
EQ7	OFF				OFF				OFF			
EQ8	OFF				OFF				OFF			
Preset 16												
Rock												
	Filter	Gain(dB)	Freq(Hz)	Q								
EQ1	PEQ	3.1	150	1								
EQ2	PEQ	-3.1	1.01k	0.7								
EQ3	PEQ	2.5	4k	1								
EQ4	OFF											
EQ5	OFF											
EQ6	OFF											
EQ7	OFF											
EQ8	OFF											

Bank4:

Preset 1					Preset 2				Preset 3			
Flat					Spoken Words				Treble Booster			
	Filter	Gain(dB)	Freq(Hz)	Q	Filter	Gain(dB)	Freq(Hz)	Q	Filter	Gain(dB)	Freq(Hz)	Q
EQ1	OFF				PEQ	-3.6	90	0.3	LSHELV	-3.1	2.5k	1
EQ2	OFF				PEQ	4.5	2k	0.2	HSHELV	3	2.5k	1
EQ3	OFF				OFF				OFF			
EQ4	OFF				OFF				OFF			
EQ5	OFF				OFF				OFF			
EQ6	OFF				OFF				OFF			
EQ7	OFF				OFF				OFF			
EQ8	OFF				OFF				OFF			
Preset 4					Preset 5				Preset 6			
Treble Reducer					Vocal Booster				F-1000			
	Filter	Gain(dB)	Freq(Hz)	Q	Filter	Gain(dB)	Freq(Hz)	Q	Filter	Gain(dB)	Freq(Hz)	Q
EQ1	LSHELV	3	2.5k	1	PEQ	-4.5	90	0.4	PEQ	5	105	2.9
EQ2	HSHELV	-3.1	2.5k	1	PEQ	4.5	1k	0.6	PEQ	4.5	600	0.9
EQ3	OFF				PEQ	-3.1	14k	0.5	PEQ	3.8	3.23k	0.8
EQ4	OFF				OFF				HPF	0	70	0.7
EQ5	OFF				OFF				OFF			
EQ6	OFF				OFF				OFF			
EQ7	OFF				OFF				OFF			
EQ8	OFF				OFF				OFF			
Preset 7					Preset 8				Preset 9			
F-1300					F-2000				H-1			
	Filter	Gain(dB)	Freq(Hz)	Q	Filter	Gain(dB)	Freq(Hz)	Q	Filter	Gain(dB)	Freq(Hz)	Q
EQ1	PEQ	5	95	2.9	PEQ	3.1	85	2.9	HPF	0	118	0.7
EQ2	PEQ	3	360	1.5	PEQ	-2	10.5k	2.9	PEQ	10	125	1.8
EQ3	OFF				OFF				PEQ	-6.5	220	1.4
EQ4	HPF	0	60	0.7	HPF	0	50	0.7	PEQ	1.5	5k	0.3
EQ5	OFF				OFF				OFF			
EQ6	OFF				OFF				OFF			
EQ7	OFF				OFF				OFF			
EQ8	OFF				OFF				OFF			
Preset 10					Preset 11				Preset 12			
H-2					H-3				SR-H2L			
	Filter	Gain(dB)	Freq(Hz)	Q	Filter	Gain(dB)	Freq(Hz)	Q	Filter	Gain(dB)	Freq(Hz)	Q
EQ1	HPF	0	63	0.7	HPF	0	63	0.7	HPF	0	20	0.5
EQ2	PEQ	10	100	1.9	PEQ	9	100	2.9	PEQ	7	100	1
EQ3	PEQ	-5	200	1.4	PEQ	-8.1	200	2.9	PEQ	-7	250	1.4
EQ4	PEQ	1.5	5k	0.4	PEQ	5	500	2.9	PEQ	-6.1	3k	1
EQ5	OFF				OFF				PEQ	2	8k	1
EQ6	OFF				OFF				OFF			
EQ7	OFF				OFF				OFF			
EQ8	OFF				OFF				OFF			
Preset 13					Preset 14				Preset 15			
SR-H3L					CS-64				CS-154/304			
	Filter	Gain(dB)	Freq(Hz)	Q	Filter	Gain(dB)	Freq(Hz)	Q	Filter	Gain(dB)	Freq(Hz)	Q
EQ1	HPF	0	20	0.5	HPF	0	100	0.7	HPF	0	100	0.7
EQ2	PEQ	7	100	1	PEQ	6	300	1.8	PEQ	5	350	1.4
EQ3	PEQ	-8.1	250	1.4	PEQ	5	1.4k	2.9	PEQ	-2.5	610	5.8
EQ4	PEQ	-4	3k	1	PEQ	2	2.8k	2.9	PEQ	3	2.1k	1.4
EQ5	PEQ	6	8k	1	PEQ	1	5k	2.9	PEQ	4	8.5k	2.9
EQ6	OFF				OFF				OFF			
EQ7	OFF				OFF				OFF			
EQ8	OFF				OFF				OFF			
Preset 16												
PC-580RU/RVU												
	Filter	Gain(dB)	Freq(Hz)	Q								
EQ1	HPF	0	50	0.7								
EQ2	PEQ	2	100	1.4								
EQ3	PEQ	5.5	350	1								
EQ4	PEQ	-2	900	1.4								
EQ5	PEQ	4	1.4k	5.8								
EQ6	PEQ	4	2.5k	5.8								
EQ7	PEQ	-2	3.5k	5.8								
EQ8	PEQ	3	7k	2.9								

11.3 Using the WP-700 remote controller

11.3.1 Connecting the WP-700

Connect WP-700 to the REMOTE CH1, CH2, CH3, CH4 RJ-45 port. The front panel REMOTE indication will light if there is WP-700 connected.

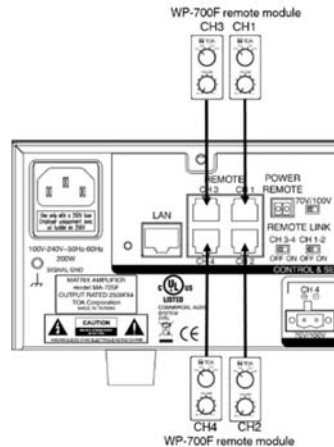

11.3.2 Remote Volume Control and Input Selection

Step 1. Connect the WP-700 to the channel that need to control remotely.

Step 2. When connected, the output volume will override the front panel OUTPUT LEVEL CONTROL to WP-700's VOLUME CONTROL. The front panel's INPUT SELECTION will be override to WP-700's INPUT SELECTION setting. The front panels

Step 3. Rotate VOLUME clockwise to increase the output level, counter-clockwise to decrease the output level.

Step 4. Input selection : same as description on 11.2.2

Note: When WP-700 connected, the front panel's OUTPUT LEVEL CONTROL and INPUT SELECTION SWITCH is not functional, it means when adjusting the output level and input selection, the WP-700 has higher control priority than front panel.

11.3.3 Remote Link

Use to control the output volume and input selection of CH1 and CH2 or CH3 and CH4 at the same time.

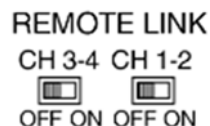

CH1-2:

ON	OFF
<p>CH1, CH2 could control the CH1 and CH2's volume and input selection by one WP-700 at the same time. The REMOTE INDICATOR on CH1 and CH2 will light at the same time.</p> <p>Note: Only connect to CH1's REMOTE TERMINAL to present remote link function</p>	<p>CH1, CH2's volume is controlled separated by two WP-700.</p>

CH3-4:

ON	OFF
<p>CH3, CH4 could control the CH1 and CH2's volume and input selection by one WP-700 at the same time. The REMOTE INDICATOR on CH3 and CH4 will light at the same time.</p> <p>Note: Only connect to CH3's REMOTE TERMINAL to present remote link function</p>	<p>CH3, CH4's volume is controlled separated by two WP-700.</p>

12. RACK MOUNTING BRACKET ATTACHMENT

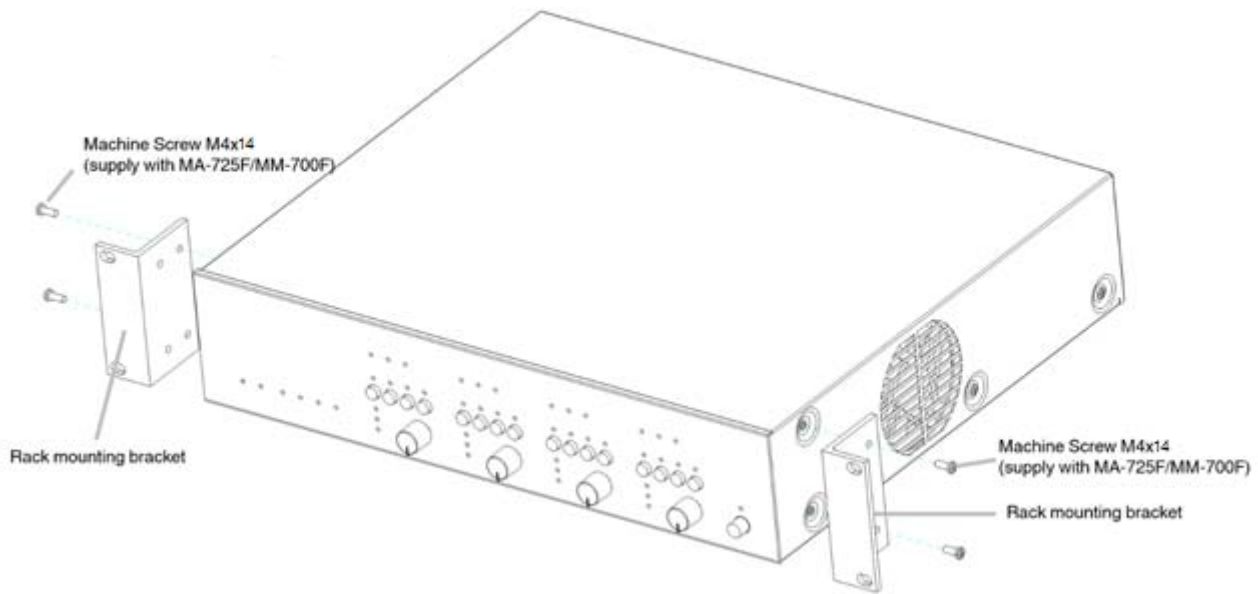

13. PROTECTION (*)

Failure	Protection	Operation Indicator	Remedy	Recovery
Continuous heavy load protection	Limit output to 1/2 rated power	Protection indicator blinks	Lower down source level or output level	Lower down source level or output level
Overcurrent due to Overload (70V <15ohm 100V< 27ohm)	Amplifier shut down	Protection indicator lights.	Remove overload	Connecting a correct load automatically restores to normal operation.
Speaker line Short circuit	Amplifier shut down	Protection indicator lights.	Check speakers and lines for short circuit	When removing short circuit after 5sec the output automatically restores to normal operation.
Temperature rise at power supply or power amp heat sink (over 75°C)	Limit output to 1/4 rated power	Protection indicator blinks	Check the unit for correct ventilation and overload.	Operation automatically returns to normal when the temperature decreases. (<65°C)
Temperature rise at power supply or power amp heat sink (over 85°C)	Amplifier shut down	Four indicators of the corresponding channel extinguish.		

(*) MA-725F only

14. BLOCK DIAGRAMS

MA-725F

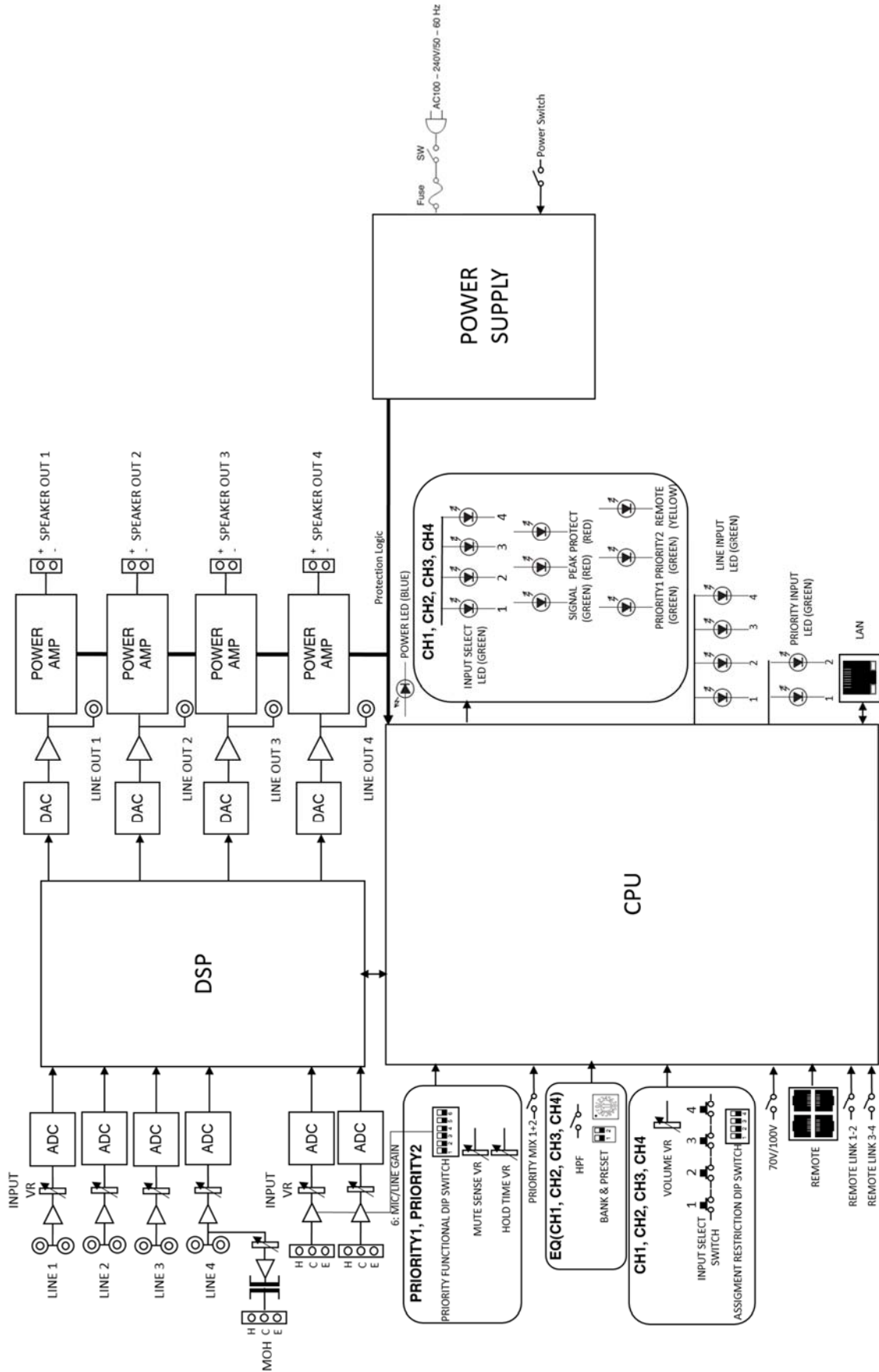

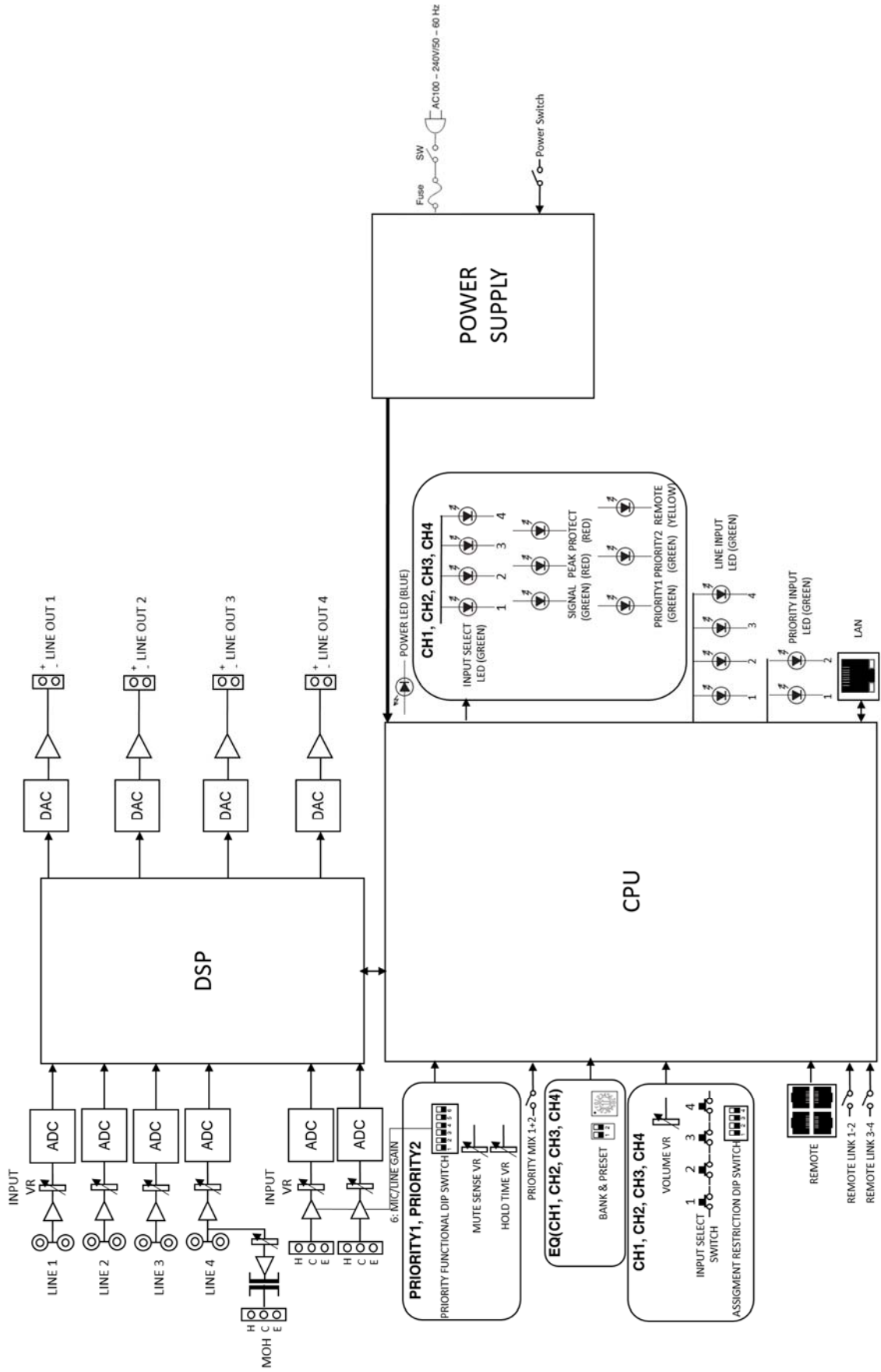

15. DIMENSIONAL DIAGRAM

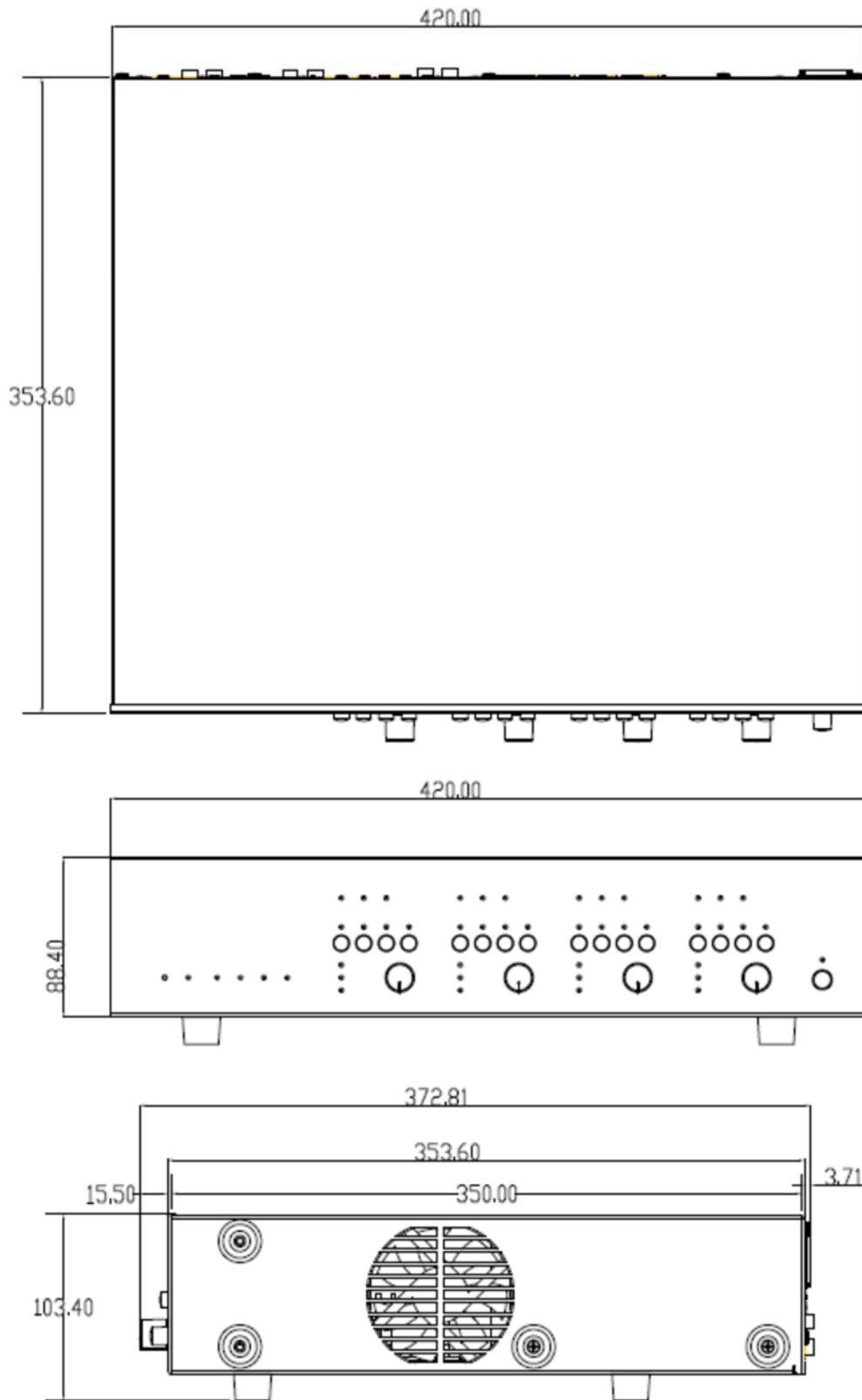

16. SPECIFICATIONS

■ SPECIFICATION

(* 0dB = 1V)

Model Number	MA-725F	
Power Source	100 - 240V AC, 50/60Hz	
Power Consumption	1350 W (rated output), 200 W (based on cULus standards), 42.5 W (idle), 22 W or less (Stand-by)	
Frequency Response	20Hz - 20 kHz (-3dB / +1dB, LPF OFF)	
Total Harmonic Distortion	1% or less, at 1kHz, rated output	
Certification	cULus 60065, EN60065, EN55032, EN55020, FCC part15 class A	
Input	PRIORITY 1, 2:	Mic -60dB* / Line -10dB* selectable, 2.2kΩ, electrically balanced, removable terminal block
	LINE IN 1,2,3,4:	-10dB*, 10kΩ, unbalanced, 2 RCA jacks (Stereo summing)
Output	SPEAKER 1,2,3,4:	70V (20Ω), 100V (40Ω), removable terminal block
	LINE OUT 1,2,3,4:	0dB*, 600Ω, unbalanced, RCA jack
	MOH:	0dB*, 600Ω, transformer balanced, removable terminal block
DSP Preset	16 presets in 4 banks at each output channel, selectable	
S/N Ratio	Mic: 60 dB* or more, Line: 75dB* or more (A-weighted)	
Muting	Manual mute / Automatic mute	
Mute Hold Time	50ms - 10 seconds, adjustable	
Priority Level	PRIORITY 1 > PRIORITY 2 > LINE 1,2,3,4	
Control	POWER:	ON/OFF switch, Power remote terminal
	PRIORITY 1,2:	MIC/LINE selector switch, Gain control, Assign switch, Auto mute switch, Mute sense control, Manual mute terminal, Mute hold time control, Priority mix switch
	LINE IN 1,2,3,4:	Gain control, Assign restriction switch
	OUTPUT 1,2,3,4:	LINE IN 1-4 selector switch, Output gain control, 70V/100V selector switch, HPF switch, DSP bank selector switch, DSP preset selector switch
	REMOTE 1,2,3,4:	Remote control connector (RJ-45), Remote link switch
Indicator	POWER:	1 Power LED
	PRIORITY 1,2:	1 Signal LED, 1 Peak LED
	LINE IN 1,2,3,4:	1 Signal LED, 1 Peak LED
	OUTPUT 1,2,3,4:	2 Activated PRIORITY LED, 1 Connected REMOTE LED, 4 Selected LINE LED 1 Signal LED, 1 Peak LED, 1 Protect LED
Operating Temperature	0°C to 40°C (32°F to 104°F)	
Operating Humidity	35% to 80%RH (no condensation)	
Finish	Panel: Aluminum, hair line, black	
	Case: Steel plate, black, paint	
Dimension	420(W) X 107.6(H) X 350(D) mm (16.54" X 4.24" X 13.78")	
Weight	7.6kg (16.7 lbs.)	
Accessories	Power cord (2m, 5.65ft.)···1, Removable terminal plug (5 pins···2, 3pins···1, 2 pins···4), Rack mounting bracket···2, Bracket mounting screw···4, User's manual···1	
Option	Remote controller: WP-700-AM	

■ SPECIFICATION

(* 0dB = 1V)

Model Number	MM-700F	
Power Source	100 - 240V AC, 50/60Hz	
Power Consumption	9W or less	
Frequency Response	20Hz - 20 kHz (-3dB / +1dB)	
Total Harmonic Distortion	1% or less, at 1kHz, rated output	
Certification	cULus 60065, EN60065, EN55032, EN55020, FCC part15 class A	
Input	PRIORITY 1, 2:	Mic -60dB* / Line -10dB* selectable, 2.2kΩ, electrically balanced, removable terminal block
	LINE IN 1,2,3,4:	-10dB*, 10kΩ, unbalanced, 2 RCA jacks (Stereo summing)
Output	LINE OUT 1,2,3,4:	0dB*, 600Ω, unbalanced, removable terminal block
	MOH:	0dB*, 600Ω, transformer balanced, removable terminal block
DSP Preset	16 presets in 4 banks at each output channel, selectable	
S/N Ratio	Mic: 60 dB* or more, Line: 75dB* or more (A-weighted)	
Muting	Manual mute / Automatic mute	
Mute Hold Time	50ms to 10 seconds, adjustable	
Priority Level	PRIORITY 1 > PRIORITY 2 > LINE 1,2,3,4	
Control	POWER:	ON/OFF switch, Power remote terminal
	PRIORITY 1,2:	MIC/LINE selector switch, Gain control, Assign switch, Auto mute switch, Mute sense control, Manual mute terminal, Mute hold time control, Priority mix switch
	LINE IN 1,2,3,4:	Gain control, Assign restriction switch
	OUTPUT 1,2,3,4:	LINE IN 1-4 selector switch, Output gain control, DSP bank selector switch, DSP preset selector switch
	REMOTE 1,2,3,4:	Remote control connector (RJ-45), Remote link switch
Indicator	POWER:	1 Power LED
	PRIORITY 1,2:	1 Signal LED, 1 Peak LED
	LINE IN 1,2,3,4:	1 Signal LED, 1 Peak LED
	OUTPUT 1,2,3,4:	2 Activated PRIORITY LED, 1 Connected REMOTE LED, 4 Selected LINE LED 1 Signal LED, 1 Peak LED
Operating Temperature	0°C to 40°C (32°F to 104°F)	
Operating Humidity	35% to 80%RH (no condensation)	
Finish	Panel: Aluminum, hair line, black	
	Case: Steel plate, black, paint	
Dimension	420(W) X 107.6(H) X 350(D) mm (16.54" X 4.24" X 13.78")	
Weight	5.7kg (12.3lbs)	
Accessories	Power cord (2m, 5.65ft.)...1, Removable terminal plug (5 pins...2, 3pins...1, 2 pins...4), Rack mounting bracket...2, Bracket mounting screw...4, User's manual...1	
Option	Remote controller: WP-700-AM	

Note: The design and specifications are subject to change without notice for improvement.

Traceability Information for Europe

Manufacturer:

TOA Corporation
7-2-1, Minatojima-Nakamachi, Chuo-ku, Kobe, Hyogo,
Japan

Authorized representative:

TOA Electronics Europe GmbH
Suederstrasse 282, 20537 Hamburg,
Germany



TOA Corporation

URL: <http://www.toa.jp/>